

# Antenna Toolbox™

## User's Guide

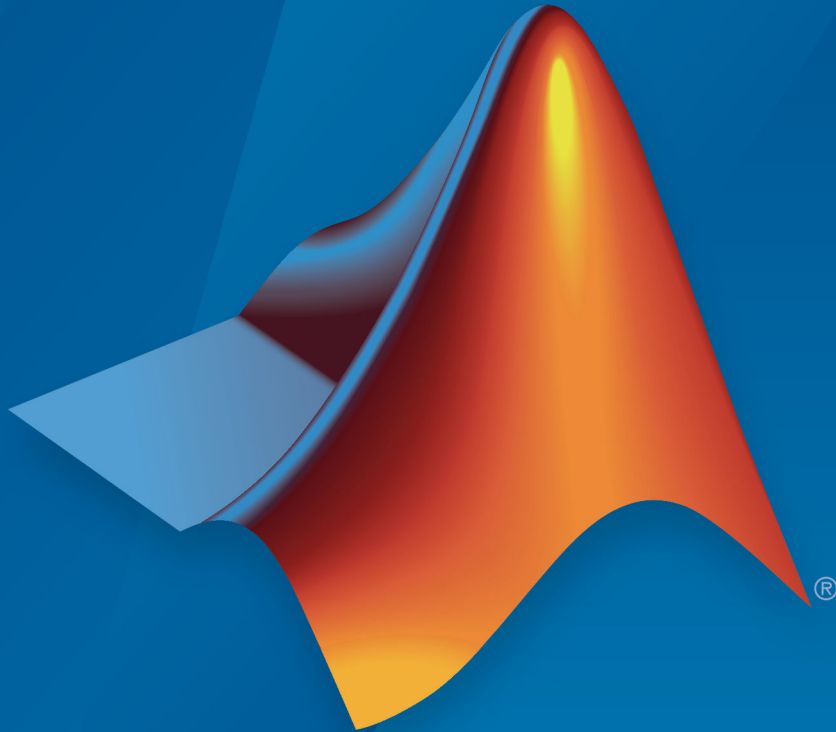

# MATLAB®

R2019a

 MathWorks®

# How to Contact MathWorks



Latest news: [www.mathworks.com](http://www.mathworks.com)  
Sales and services: [www.mathworks.com/sales\\_and\\_services](http://www.mathworks.com/sales_and_services)  
User community: [www.mathworks.com/matlabcentral](http://www.mathworks.com/matlabcentral)  
Technical support: [www.mathworks.com/support/contact\\_us](http://www.mathworks.com/support/contact_us)



Phone: 508-647-7000



The MathWorks, Inc.  
1 Apple Hill Drive  
Natick, MA 01760-2098

## *Antenna Toolbox™ User's Guide*

© COPYRIGHT 2015–2019 by The MathWorks, Inc.

The software described in this document is furnished under a license agreement. The software may be used or copied only under the terms of the license agreement. No part of this manual may be photocopied or reproduced in any form without prior written consent from The MathWorks, Inc.

FEDERAL ACQUISITION: This provision applies to all acquisitions of the Program and Documentation by, for, or through the federal government of the United States. By accepting delivery of the Program or Documentation, the government hereby agrees that this software or documentation qualifies as commercial computer software or commercial computer software documentation as such terms are used or defined in FAR 12.212, DFARS Part 227.72, and DFARS 252.227-7014. Accordingly, the terms and conditions of this Agreement and only those rights specified in this Agreement, shall pertain to and govern the use, modification, reproduction, release, performance, display, and disclosure of the Program and Documentation by the federal government (or other entity acquiring for or through the federal government) and shall supersede any conflicting contractual terms or conditions. If this License fails to meet the government's needs or is inconsistent in any respect with federal procurement law, the government agrees to return the Program and Documentation, unused, to The MathWorks, Inc.

### **Trademarks**

MATLAB and Simulink are registered trademarks of The MathWorks, Inc. See [www.mathworks.com/trademarks](http://www.mathworks.com/trademarks) for a list of additional trademarks. Other product or brand names may be trademarks or registered trademarks of their respective holders.

### **Patents**

MathWorks products are protected by one or more U.S. patents. Please see [www.mathworks.com/patents](http://www.mathworks.com/patents) for more information.

### **Revision History**

|                |             |                                  |
|----------------|-------------|----------------------------------|
| March 2015     | Online only | New for Version 1.0 (R2015a)     |
| September 2015 | Online only | Revised for Version 1.1 (R2015b) |
| March 2016     | Online only | Revised for Version 2.0 (R2016a) |
| September 2016 | Online only | Revised for Version 2.1 (R2016b) |
| March 2017     | Online only | Revised for Version 2.2 (R2017a) |
| September 2017 | Online only | Revised for Version 3.0 (R2017b) |
| March 2018     | Online only | Revised for Version 3.1 (R2018a) |
| September 2018 | Online only | Revised for Version 3.2 (R2018b) |
| March 2019     | Online only | Revised for Version 4.0 (R2019a) |

|   |             |
|---|-------------|
| <b>Port Analysis</b> .....                              | <b>1-2</b>  |
| Input Impedance .....                                   | <b>1-3</b>  |
| Resonance .....   | <b>1-5</b>  |
| Reflection Coefficient .....                            | <b>1-6</b>  |
| Return Loss .....                                       | <b>1-7</b>  |
| Voltage Standing Wave Ratio .....                       | <b>1-9</b>  |
| Bandwidth .....   | <b>1-10</b> |
| <br>  |             |
| <b>Surface Analysis</b> .....                           | <b>1-12</b> |
| Charge Distribution .....                               | <b>1-12</b> |
| Current Distribution .....                              | <b>1-16</b> |
| <br>  |             |
| <b>Meshing</b> .....                                    | <b>1-20</b> |
| Automatic Meshing Mode .....                            | <b>1-20</b> |
| Manual Meshing Mode .....                               | <b>1-22</b> |
| Strip Meshing .....                                     | <b>1-23</b> |
| Surface Meshing .....                                   | <b>1-24</b> |
| Meshing a Dielectric Substrate .....                    | <b>1-25</b> |
| <br>  |             |
| <b>Field Analysis</b> .....                             | <b>1-27</b> |
| Radiation Pattern .....                                 | <b>1-27</b> |
| Beamwidth .....   | <b>1-32</b> |
| E-Plane and H Plane .....                               | <b>1-33</b> |
| Polarization .....                                      | <b>1-35</b> |
| Axial Ratio .....                                       | <b>1-39</b> |
| <br>  |             |
| <b>Rotate Antenna and Arrays</b> .....                  | <b>1-41</b> |
| Rotate Single Antenna Element .....                     | <b>1-41</b> |
| Rotate Single Antenna Element About Multiple Axis ..... | <b>1-44</b> |
| Rotate Dipole Backed Reflector .....                    | <b>1-45</b> |
| Rotate Antenna Array Elements .....                     | <b>1-48</b> |

|  |             |
|--|-------------|
| <b>Infinite Ground Plane</b> .....                               | <b>1-50</b> |
| Image Theory .....   | <b>1-50</b> |
| Formulate the Image Theory Technique .....                       | <b>1-51</b> |
| <b>Model Infinite Ground Plane for Balanced Antennas</b> .....   | <b>1-55</b> |
| <b>Model Infinite Ground Plane for Unbalanced Antennas</b> ..... | <b>1-60</b> |

## Array Concepts

# 2

|   |             |
|---|-------------|
| <b>Mutual Coupling</b> .....  | <b>2-2</b>  |
| Active or Scan Impedance .....                                      | <b>2-2</b>  |
| Mutual Impedance .....  | <b>2-3</b>  |
| Coupling Matrix .....   | <b>2-4</b>  |
| Array Factor and Pattern Multiplication .....                       | <b>2-6</b>  |
| Isolated Element Pattern .....                                      | <b>2-12</b> |
| Embedded Element Pattern .....                                      | <b>2-13</b> |
| <b>Beamforming</b> .....  | <b>2-15</b> |
| Side Lobe Control .....   | <b>2-15</b> |
| Beam Scanning .....   | <b>2-17</b> |
| <b>Grating Lobes</b> .....  | <b>2-20</b> |
| <b>Correlation Coefficient</b> .....                                | <b>2-23</b> |
| Far-Field Radiation Pattern .....                                   | <b>2-23</b> |
| S-Parameter Characterization .....                                  | <b>2-23</b> |
| <b>Infinite Arrays</b> .....  | <b>2-25</b> |
| What Are Infinite Arrays? .....                                     | <b>2-25</b> |
| Infinite Array Analysis .....                                       | <b>2-25</b> |
| Create Infinite Array Using Antenna Toolbox .....                   | <b>2-26</b> |
| Choose a Unit Cell .....  | <b>2-27</b> |
| Scan Infinite Arrays .....  | <b>2-30</b> |
| Scan Impedance and Scan Element Pattern .....                       | <b>2-30</b> |
| Compare Scan Element Pattern of Finite and Infinite Arrays<br>..... | <b>2-31</b> |
| Impact of Infinite Double Summation .....                           | <b>2-37</b> |

|  |             |
|--|-------------|
| <b>Manipulate Array Elements</b> ..... | <b>2-41</b> |
|--|-------------|

## Computational Techniques

### 3

|  |                 |
|--|-----------------|
| <b>Method of Moments Solver for Metal Structures</b> .....                         | <b>3-2</b>      |
| MoM Formulation .....  | <b>3-2</b>      |
| Neighbor Region .....  | <b>3-6</b>      |
| Singularity Extraction .....   | <b>3-7</b>      |
| Finite Arrays .....  | <b>3-8</b>      |
| Infinite Array .....   | <b>3-9</b>      |
| <br><b>Method of Moments Solver for Metal and Dielectric Structures</b><br>.....   | <br><b>3-11</b> |
| MoM Formulation .....  | <b>3-11</b>     |
| Neighbor Region .....  | <b>3-14</b>     |
| Singularity Extraction .....   | <b>3-16</b>     |
| Finite Arrays .....  | <b>3-16</b>     |
| Infinite Array .....   | <b>3-17</b>     |
| <br><b>Hybrid MoM-PO Method for Metal Antennas with Large<br/>Scatterers</b> ..... | <br><b>3-19</b> |
| Subdomain RWG Basis Functions and Extra Dimensions ....                            | <b>3-19</b>     |
| MoM Region and PO Region .....   | <b>3-21</b>     |
| MoM Solution and PO Solution .....   | <b>3-22</b>     |
| Finding ZPO .....  | <b>3-23</b>     |
| Direct Solution Method .....   | <b>3-24</b>     |

## RF Propagation

### 4

|   |            |
|---|------------|
| <b>Site Viewer</b> .....                                  | <b>4-2</b> |
| Introduction .....  | <b>4-2</b> |
| Dimension Picker .....                                    | <b>4-3</b> |
| Basemaps .....  | <b>4-4</b> |
| View Latitude and Longitude Coordinates of Location ..... | <b>4-8</b> |

|   |             |
|---|-------------|
| <b>Troubleshooting Site Viewer</b> .....                | <b>4-10</b> |
| Internet Connection Failure .....                       | <b>4-10</b> |
| Graphics Environment .....                              | <b>4-10</b> |
| <b>Access Basemaps and Terrain in Site Viewer</b> ..... | <b>4-12</b> |
| Access and Download Basemaps .....                      | <b>4-12</b> |
| Access Terrain .....                                    | <b>4-13</b> |
| <b>Access TIREM Software</b> .....                      | <b>4-14</b> |

# Antenna Concepts

---

- “Port Analysis” on page 1-2
- “Surface Analysis” on page 1-12
- “Meshing” on page 1-20
- “Field Analysis” on page 1-27
- “Rotate Antenna and Arrays” on page 1-41
- “Infinite Ground Plane” on page 1-50
- “Model Infinite Ground Plane for Balanced Antennas” on page 1-55
- “Model Infinite Ground Plane for Unbalanced Antennas” on page 1-60

## Port Analysis

| In this section...                        |
|---|
| “Input Impedance” on page 1-3             |
| “Resonance” on page 1-5                   |
| “Reflection Coefficient” on page 1-6      |
| “Return Loss” on page 1-7                 |
| “Voltage Standing Wave Ratio” on page 1-9 |
| “Bandwidth” on page 1-10                  |

The *port* of an antenna is the physical location where the RF source is connected. From a network theory perspective, the antenna has a single port. In Antenna Toolbox, a red dot on the antenna figure represents the feed point. A half-wavelength dipole is shown with its feed point:



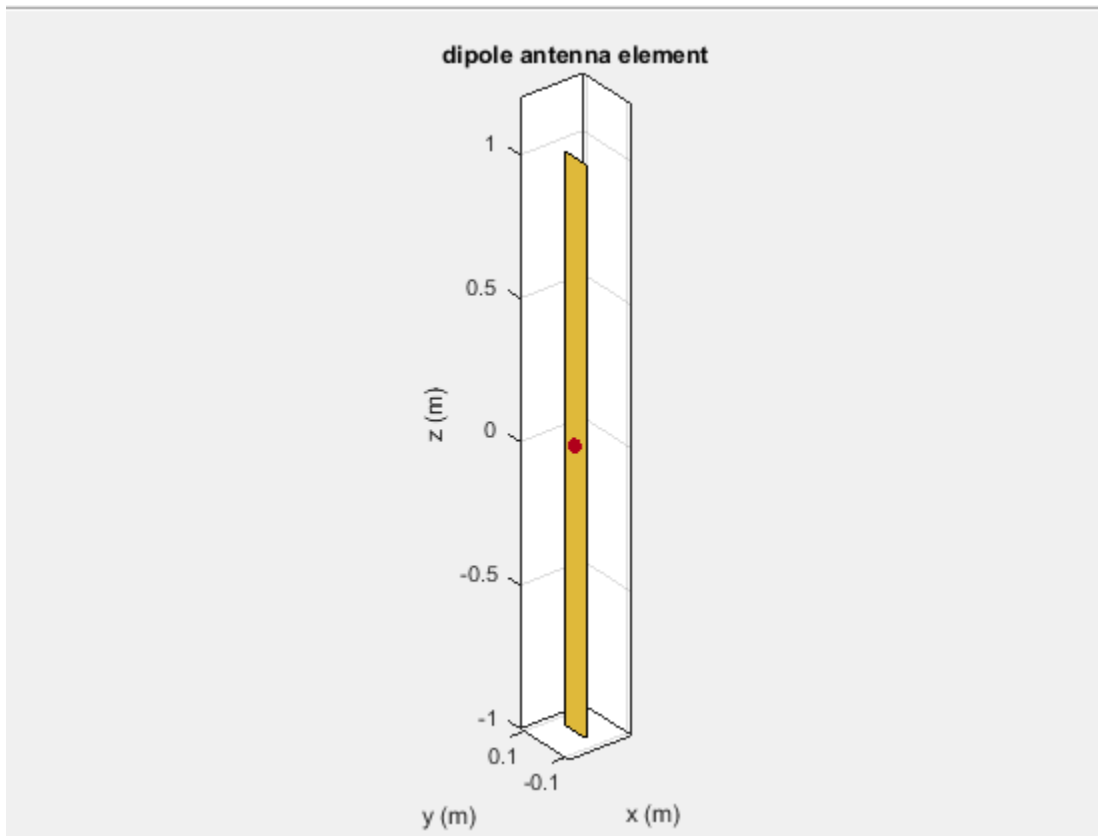

All antennas are excited by a voltage of 1V at the port. The various terminal port parameters are as follows:

## Input Impedance

*Input impedance* is the ratio of voltage to current at the port. Antenna impedance is calculated as the ratio of the phasor voltage, which is 1V at a phase angle of  $\theta$  deg, to the phasor current at the port. The impedance equation is:

$$Z = V/I = R + jX$$

where:

- $V$  is the antenna excitation voltage
- $I$  is the current
- $R$  is the antenna resistance in ohms
- $X$  is the antenna reactance in ohms

Antenna input impedance is a frequency-dependent quantity. The plot shows the input impedance of a dipole antenna over the frequency band 20-120 MHz. The resistance and reactance traces vary with frequency. The variation can be qualitatively described in terms of resonances.

`d = dipole;`  
`impedance(d,20e6:1e6:120e6)`

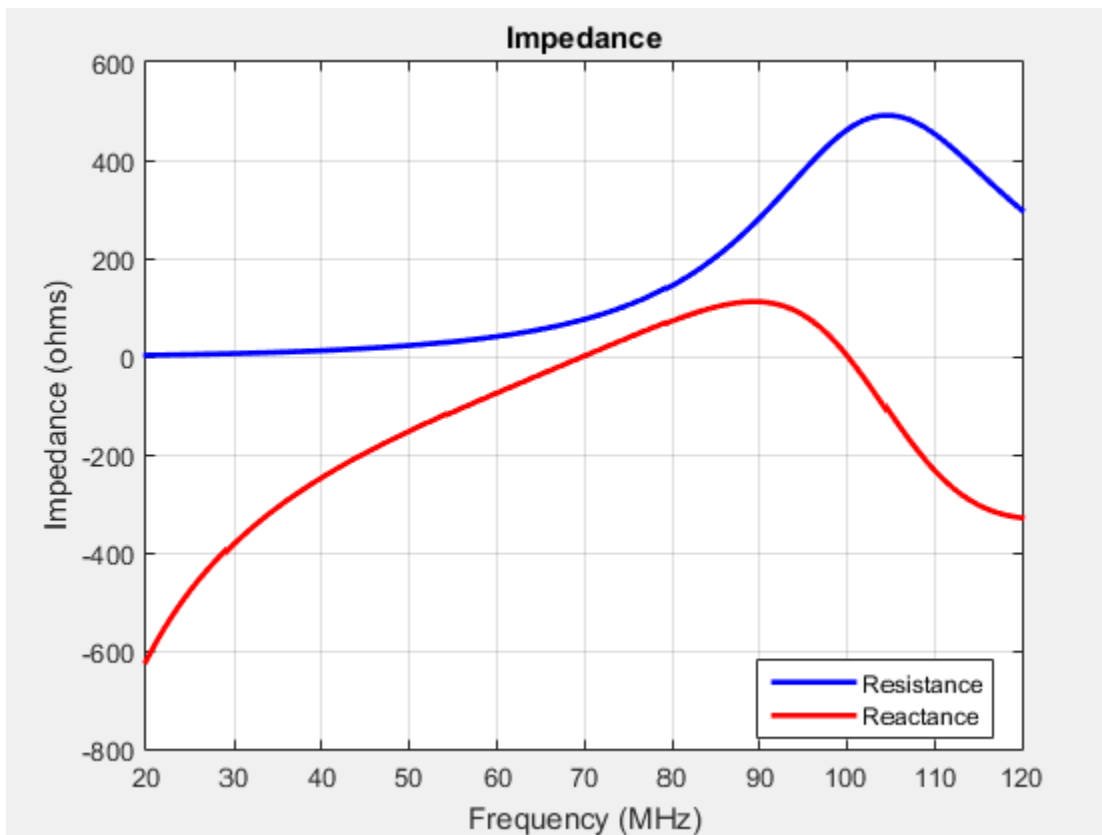

Use impedance to calculate the input impedance of any antennas in Antenna Toolbox.

## Resonance

The *resonant frequency* of the antenna is the frequency at which the reactance of the antenna is equal to zero.

The plot shows two resonance points of a dipole antenna.

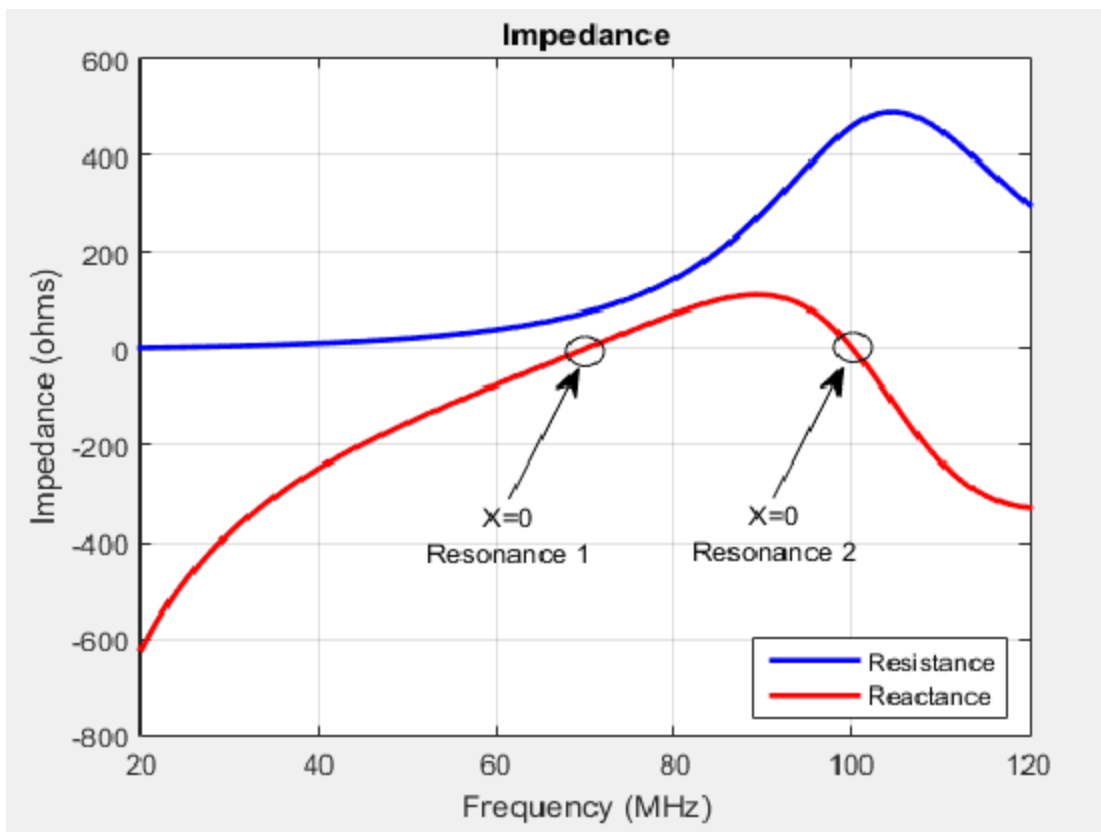

In the plot, the reactance values are negative, or capacitive, before the resonance. These values are positive or inductive after the resonance. This type of resonance is called series resonance. You can model this type of resonance using a series RLC circuit. If the

impedance curve goes from positive reactance to negative reactance, it is called parallel resonance. You can model this type of resonance using a parallel RLC circuit.

## Reflection Coefficient

The *reflection coefficient*, or  $S_{11}$ , of the antenna describes a relative fraction of the incident RF power that is reflected back due to the impedance mismatch. Impedance mismatch is the difference between the input impedance of the antenna and the characteristic impedance of the transmission line (or the generator impedance when the transmission line is not present). The characteristic impedance is the reference impedance.

```
S = sparameters(d, 20e6:1e6:120e6, 72)
rfplot(S)
```

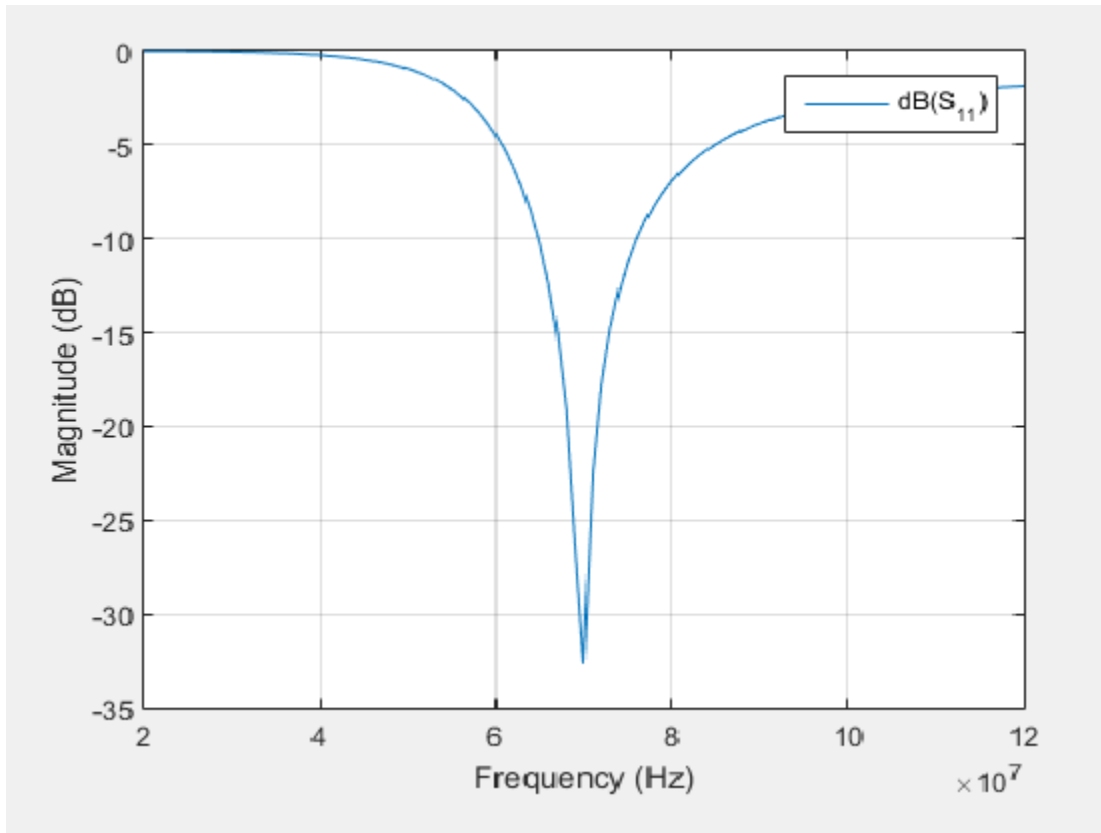

The reflection coefficient also gives the operating bandwidth of the antenna. Antenna bandwidth is usually the frequency band over which the magnitude of the reflection coefficient is below -10 dB.

Use `sparameters` to calculate the value of  $S_{11}$  for any antenna in the Antenna Toolbox.

## Return Loss

The *return loss* of an antenna is a measure of the effectiveness of power delivery from a transmission line or coaxial cable to a load such as an antenna. The return loss can also be defined as the difference in dB between the power sent toward the antenna and the power reflected back from it. The higher the power ratio, the better matching between load and line. Return loss equation is:

$$RL = -20\log_{10}|S_{11}|$$

where:

- RL is the return loss
- $S_{11}$  is the reflection coefficient, or power reflected from the antenna.

For passive devices, the return loss is a positive nondissipative term representing the reduction in amplitude of the reflected wave in comparison to the incident wave. In active devices, a negative return loss is possible.

```
d = dipole;  
returnLoss(d,20e6:1e6:120e6,72)
```

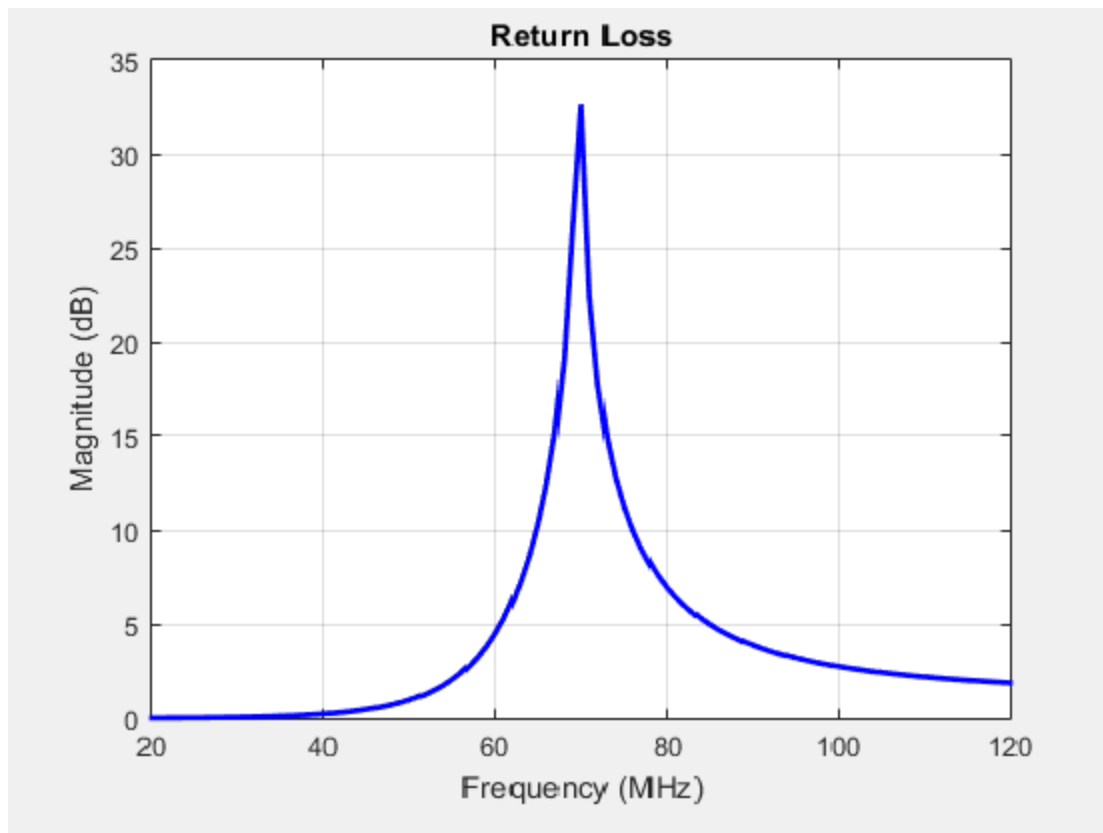

Return loss plots also give the operating bandwidth of the antenna. Antenna bandwidth is the frequency band over which the magnitude of return loss is greater than 10 dB. Use the `returnLoss` function to calculate the return loss of any antenna in the Antenna Toolbox library.

## Voltage Standing Wave Ratio

The *voltage standing wave ratio* (VSWR) of an antenna is another measure of impedance matching between transmission line and antenna. The standing wave is generated because of the impedance mismatch at the port. VSWR equation is:

$$VSWR = \frac{1 + |S_{11}|}{1 - |S_{11}|}$$

where:

- $S_{11}$  is the reflection coefficient.

```
d = dipole;  
vswr(d,20e6:1e6:120e6,72)  
axis([20 120 1 20])
```

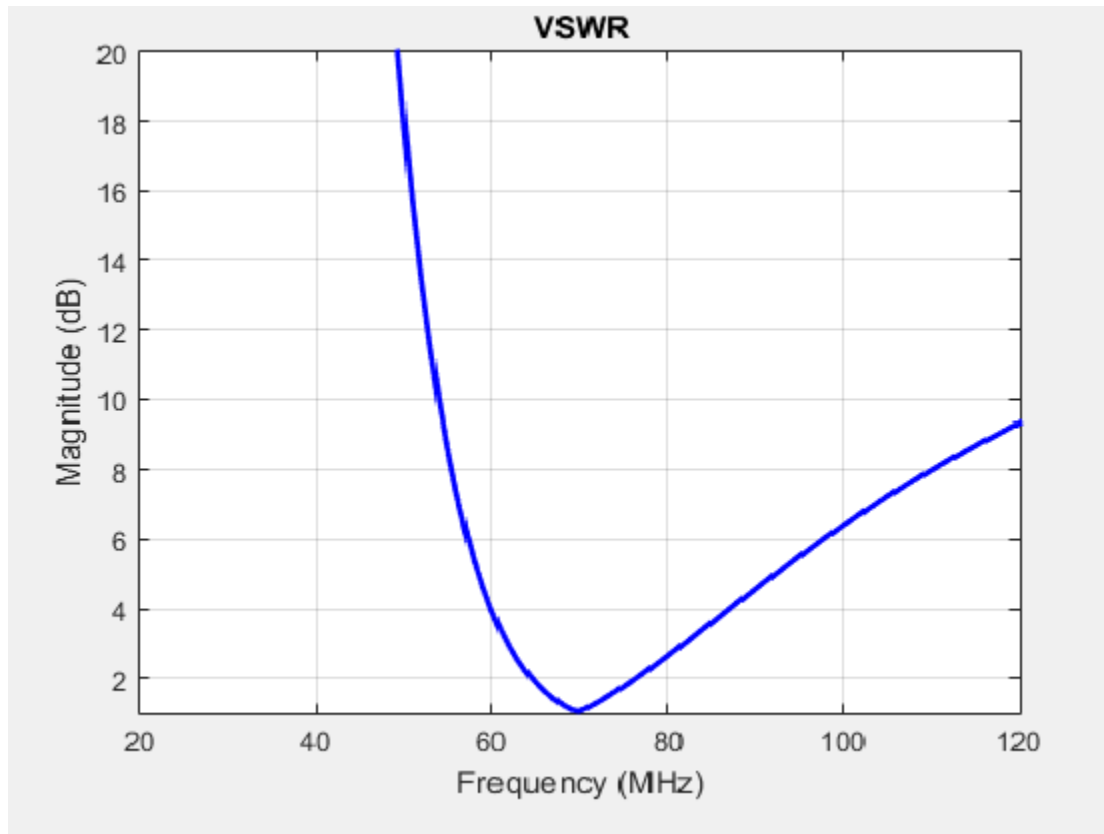

VSWR is scalar and contains no phase information. The value of VSWR lies between 1 and infinity. Antenna bandwidth is usually the frequency band over which the VSWR is less than approximately 2.

Use `vswr` to calculate the voltage standing wave ratio for any antenna in Antenna Toolbox.

## Bandwidth

*Bandwidth* describes the range of frequencies over which the antenna can properly radiate or receive energy. It is a fundamental antenna parameter. Often, the desired bandwidth is one of the parameters used to determine which antenna to use. Antenna bandwidth is usually the frequency band over which the magnitude of the reflection



coefficient is below -10 dB, or the magnitude of the return loss is greater than 10 dB, or the VSWR is less than approximately 2. All these criteria are equivalent. You can control the bandwidth using proper antenna design.

## References

- [1] Balanis, C.A. *Antenna Theory: Analysis and Design*. 3rd Ed. New York: Wiley, 2005.
- [2] Stutzman, Warren L., and Thiele, Gary A. *Antenna Theory and Design*. 3rd Ed. New York: Wiley, 2013.
- [3] Bird, T.S. "Definition and Misuse of Return Loss." *IEEE Antennas and Propagation Magazine*. Vol. 51, Issue 2, April 2009, pp. 166-167.

## Surface Analysis

|                                     |
|-------------------------------------|
| <b>In this section...</b>           |
| “Charge Distribution” on page 1-12  |
| “Current Distribution” on page 1-16 |

### Charge Distribution

The flow of charges on the antenna surface determines the surface currents of the antenna. For antennas to radiate, there must be acceleration or deceleration of charges. The deceleration of charges is caused due to buildup of charges at the end of the wire, which leads to impedance discontinuities. This mechanism creates electromagnetic radiation. The accumulation of charges varies according to time and structure of the antenna.

The accumulation of charges is exploited in many ways. If you calculate the impedance of this monopole antenna using the impedance function, you get the following plot:

```
m = monopole  
impedance(m, 20e6 : 1e6 : 120e6)
```

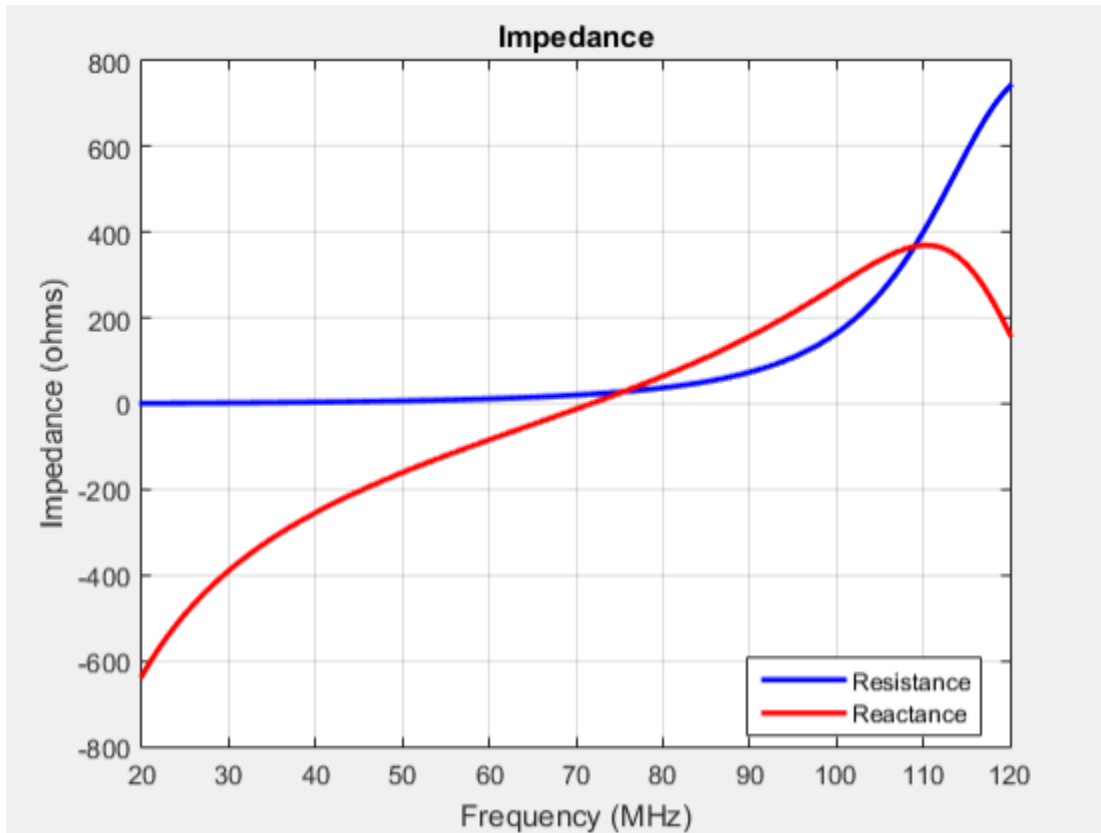

You can observe the first resonance is at approximately 71 MHz. To lower the resonance frequency, recalculate the height of the monopole to quarter wavelength. The frequency of operation is also lower. You must also have to increase the size of the corresponding ground plane. This increase in size means that to achieve similar performance at a lower frequency, you need a larger antenna. This approach is not possible due to physical space constraints.

Alternatively, you can exploit the fact that antennas have charge accumulation. If you provide appropriate structural modification to the antenna, charges accumulate. For a monopole antenna, you can enable charge accumulation by adding a top-hat to the monopole. Now, if you calculate the impedance of the antenna using the top-hat, the plot is:

```
mt = monopoleTopHat  
impedance(mt, 20e6:1e6:120e6)
```

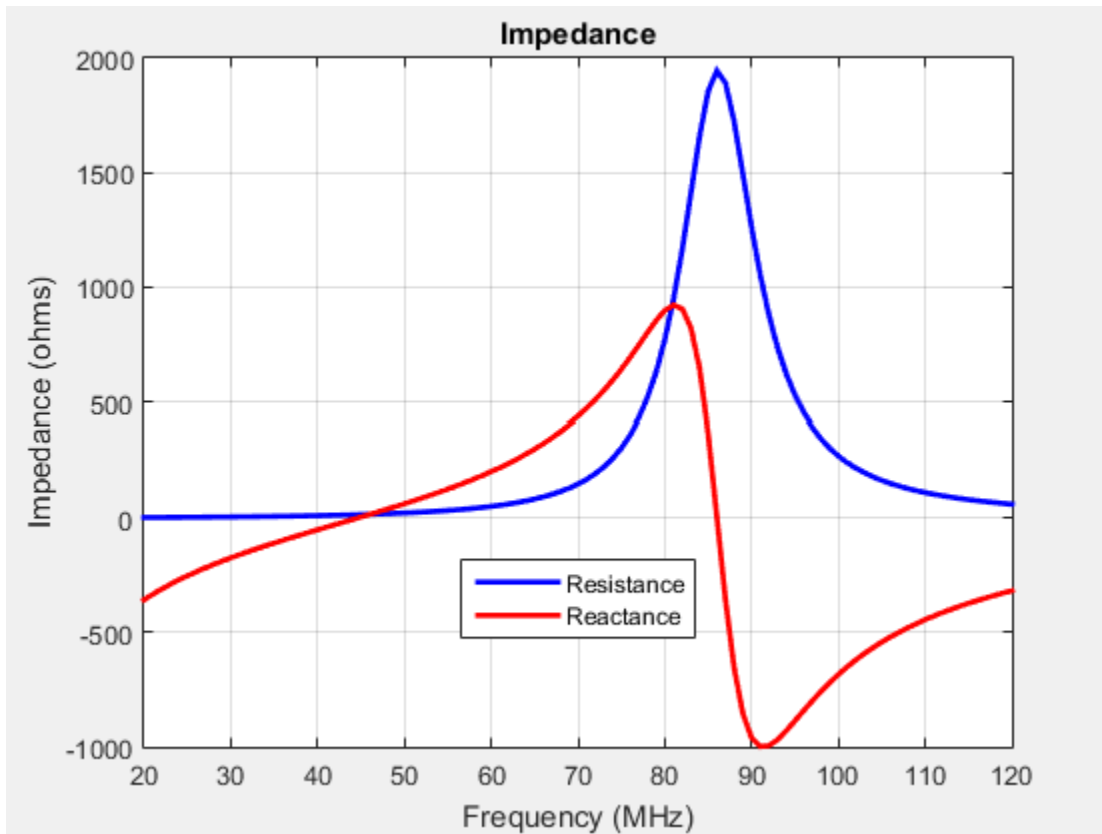

All the dimensions of this antenna are same as the monopole. The first resonance of the antenna is approximately 45 MHz. To view the accumulated charges on the top-hat monopole, use the charge function:

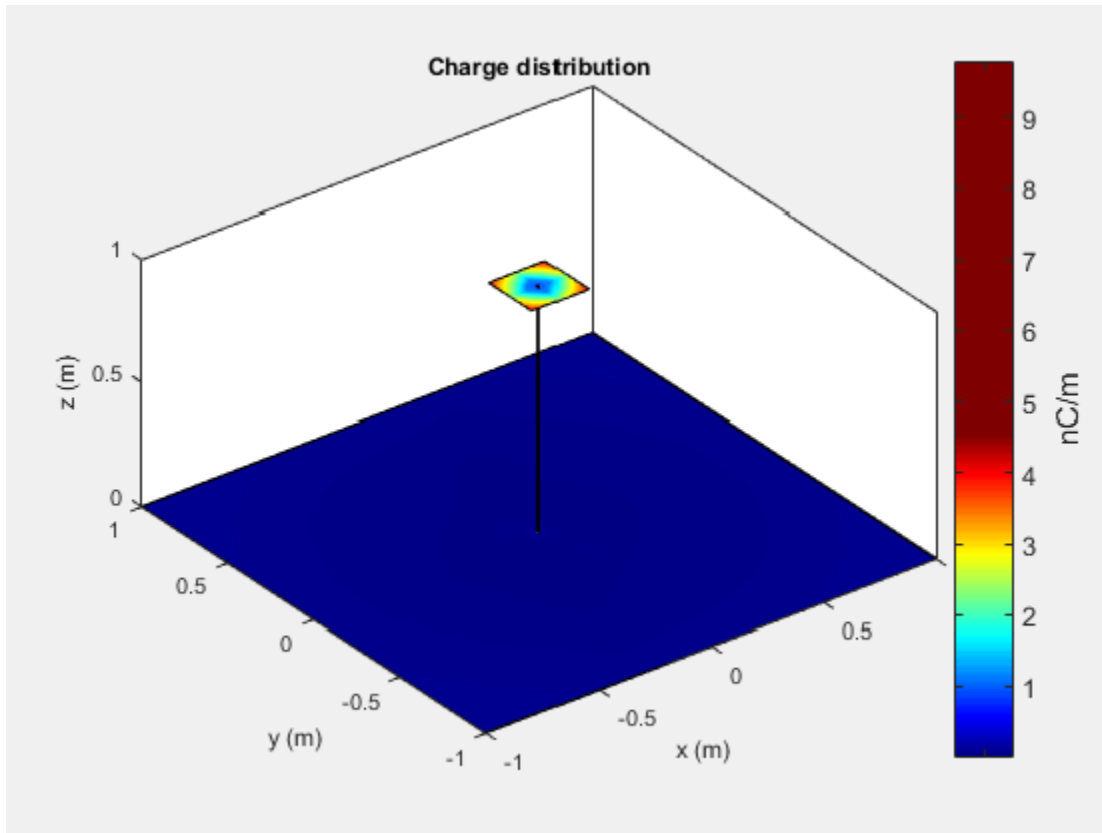

The increase in capacitance lowers the frequency of the antenna. By keeping the physical volume of the antenna same, the resonance point is shifted.

Increasing the top-hat dimensions provides more surface area for charges to accumulate. More charge accumulation increases the capacitance and pushes the resonant frequency lower. For example:

```
mt.TopHatLength = 0.35
mt.TopHatWidth = 0.35
impedance(mt,20e6:1e6:120e6)
```

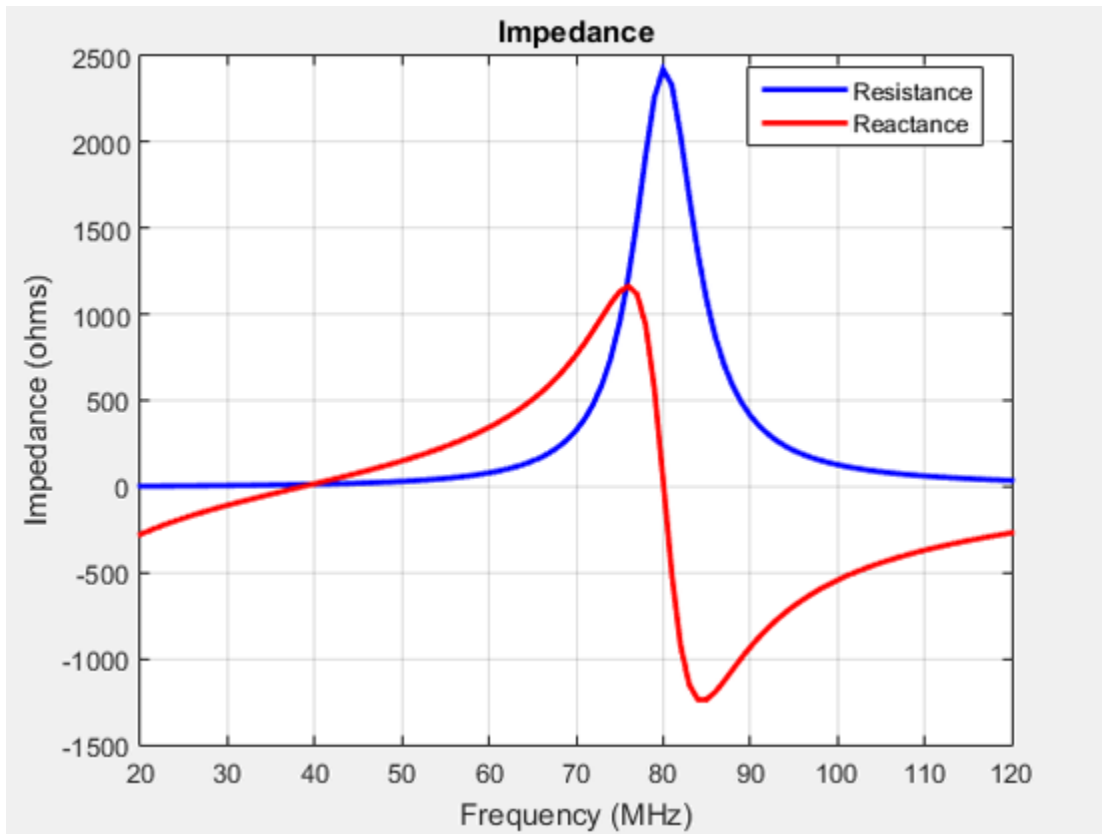

The resonance of the antenna further reduces to approximately 40 MHz.

## Current Distribution

A typical antenna surface has current flowing on it. The behavior of the antenna surface current depends on the frequency of the input source, the geometry of the antenna, and the material properties of the antenna. The current is a vector and is spatially related to the structure of the antenna. In a dipole antenna, the maximum current distribution is in the middle of the antenna and the minimum is toward the end:

```
d = dipole;  
current(d, 70e6)
```

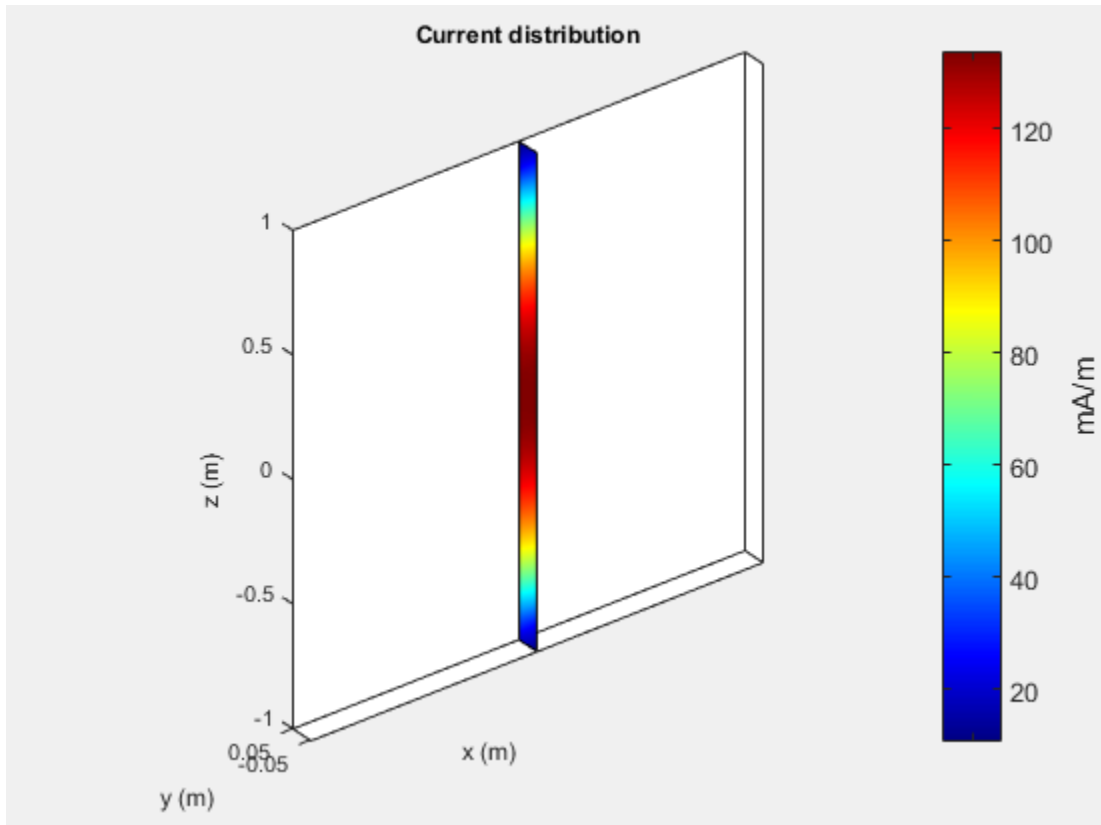

The same is true for a spiral antenna:

```
s = spiralEquiangular;  
current(s,4e9)
```

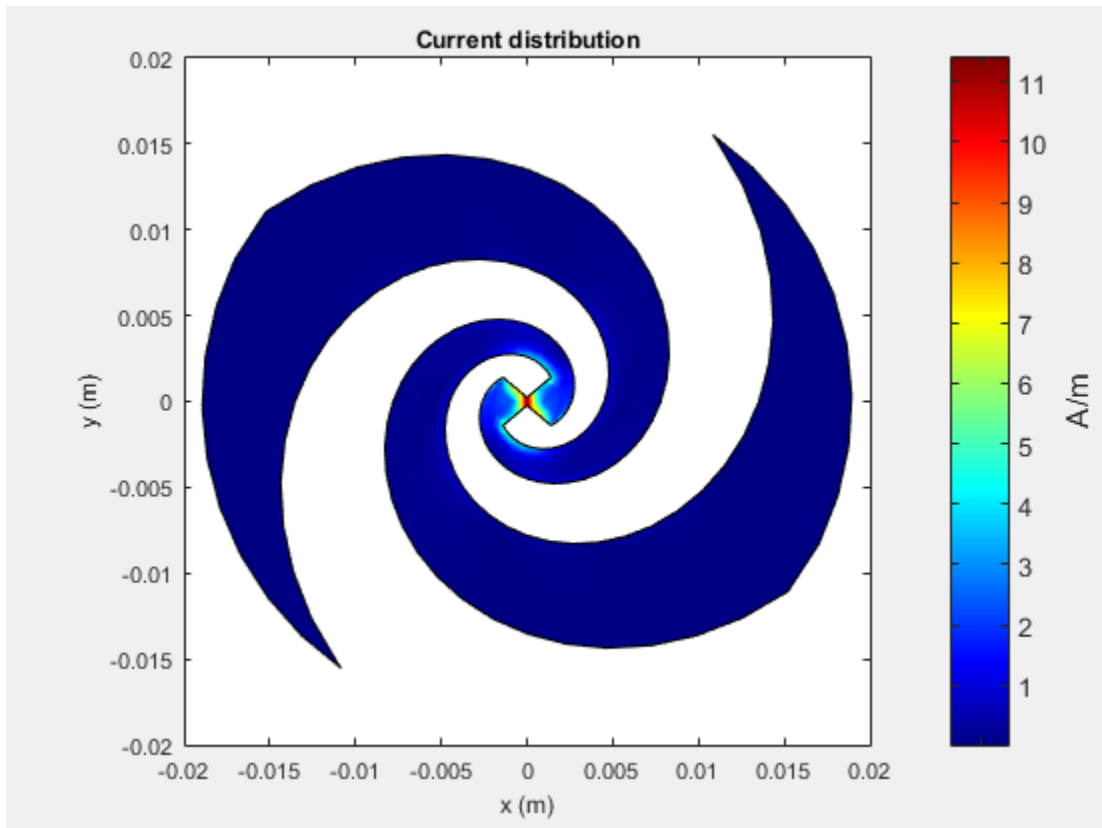

The patch also shows the current distribution of the classic  $\lambda/2$  open-open resonator. The two ends of the patch represent an open circuit since the current is at a minimum.

```
pm = patchMicrostrip;  
current(pm,1.75e9)
```



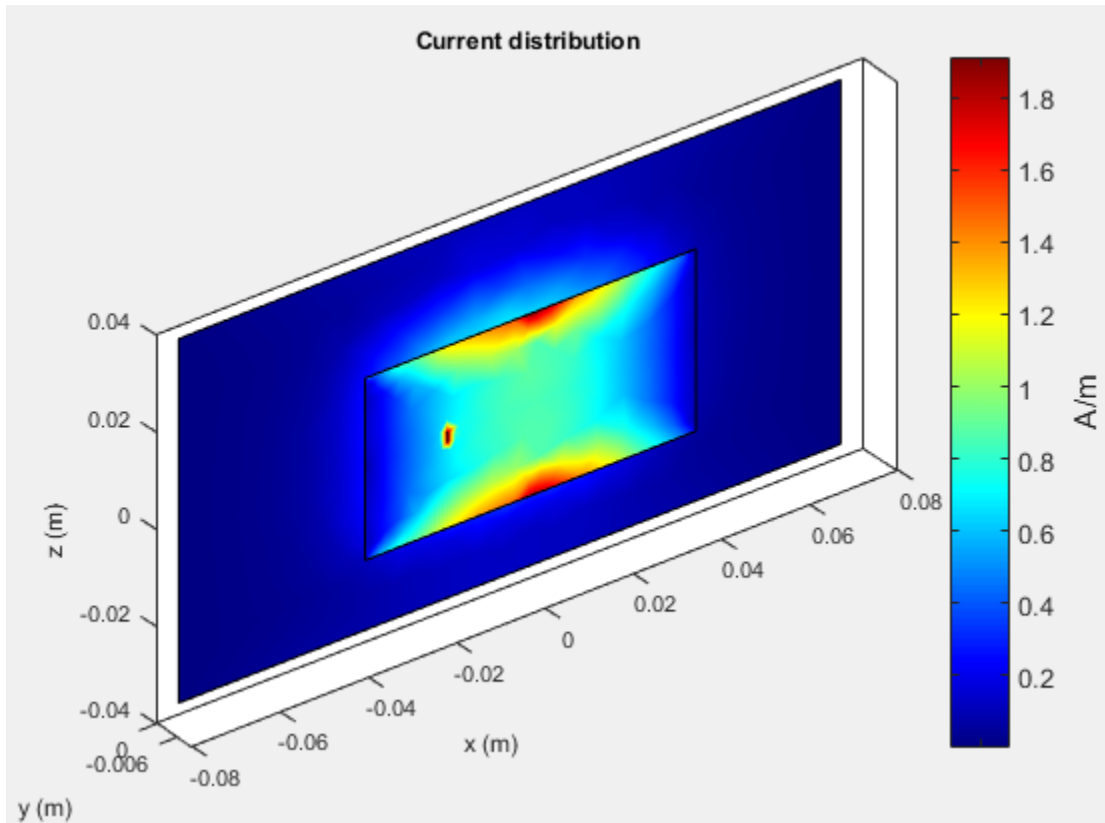

The spatial relationship between the current and structure of antenna is termed mode.

## References

- [1] Balanis, C.A. *Antenna Theory. Analysis and Design*, 3rd Ed. New York: Wiley, 2005.
- [2] Makarov, S.N. *Antenna and EM Modeling with MATLAB*, New York: Wiley & Sons, 2002, p. 66.

## Meshing

| In this section...                            |
|---|
| “Automatic Meshing Mode” on page 1-20         |
| “Manual Meshing Mode” on page 1-22            |
| “Strip Meshing” on page 1-23                  |
| “Surface Meshing” on page 1-24                |
| “Meshing a Dielectric Substrate” on page 1-25 |

Method of Moments (MoM) is a numerical method that transforms Maxwell’s continuous integral equations into an approximate discrete formulation that requires inversion of a large matrix. *Meshing* is the process of converting the continuous domain into the discrete domain for solving the equations. For discretizing surfaces, typically either triangles or rectangles are used. Antenna Toolbox uses triangular element for meshing as it conforms better for arbitrary shaped surfaces. The triangles are used to approximate the surface current using the Rao-Wilton-Glisson (RWG) basis functions. To get an accurate result, ensure that large number of triangles are present in the region where current variation is the highest. This region is typically either the corners in the antenna geometry or at the point where the antenna is excited.

### Automatic Meshing Mode

In Antenna Toolbox, the antenna structures mesh automatically based on the analysis frequency chosen. For analysis functions that accept a scalar frequency, the antennas mesh at that single frequency to satisfy the minimum triangles required. Then the functions calculate the corresponding antenna parameter.

```
d = dipole;  
impedance(d,75e6);  
mesh(d)
```

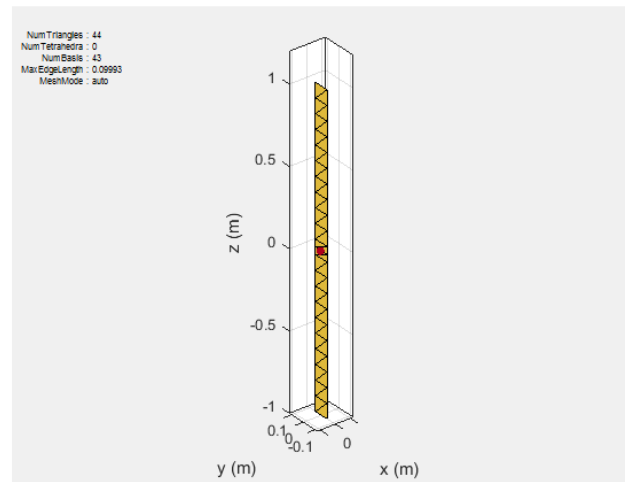
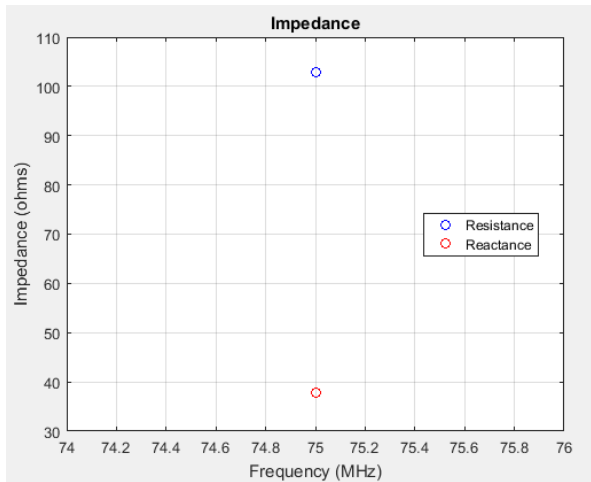

In above example, the dipole is meshed at 75 MHz automatically before calculating the impedance at that value. Use the mesh command to view the meshed dipole. The number of triangles is 44.

For analysis functions that accept a frequency vector (`impedance`, `sparameters`, `returnLoss`, `vswr`), each antenna meshes once at the highest frequency. Then, the functions calculate the corresponding antenna parameters at all the frequencies in the range.

```
d = dipole;
impedance(d, 75e6:1e6:85e6);
mesh(d)
```

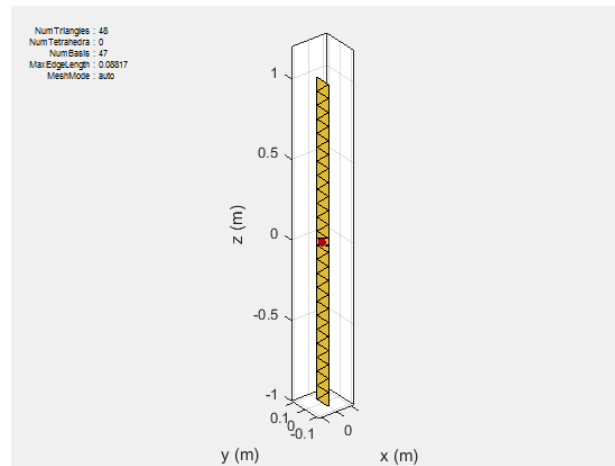
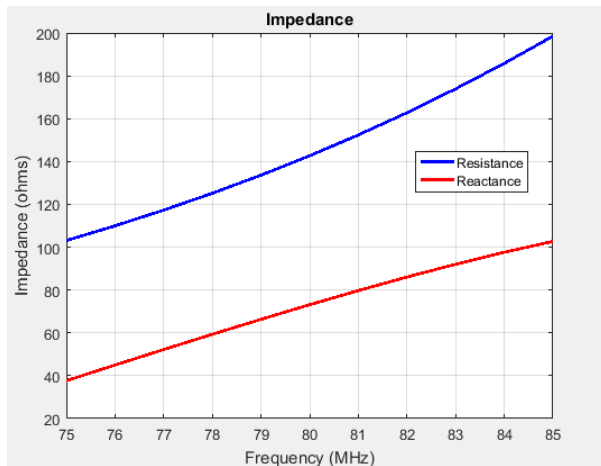

In above example, the dipole is meshed at the highest frequency, 85 MHz automatically before calculating the impedance at all the frequencies from 75 to 85 MHz. Meshing at the highest frequency, 85 MHz, ensures maximum number of triangles and a smoother plot of the dipole impedance. Use the mesh command to view the meshed dipole. The number of triangles is 48, which is more than single frequency meshing.

## Manual Meshing Mode

You can choose to mesh the structure manually at the highest frequency of interest. Manual meshing is done by specifying the maximum edge length that is used for discretizing the structure. One option is to specify the value to be one-tenth of the wavelength at the highest frequency of interest. For example:

```
sp      = spiralArchimedean;
freq    = 0.8e9:100e6:2.5e9;
lambda  = 3e8/freq(end);
mesh(sp, 'MaxEdgeLength', lambda/10);
```

Alternatively, you can run an analysis at the highest frequency of interest and get the maximum edge length. Specify this maximum edge length using the mesh function as shown. This mesh is used for all other calculations.

```
sp      = spiralArchimedean;
freq    = 0.8e9:100e6:2.5e9;
temp    = axialRatio(sp, freq(end), 0, 90);
```

```
meshdata = mesh(sp);  
mesh(sp, 'MaxEdgeLength', meshdata.MaxEdgeLength);
```

## Strip Meshing

For strip meshing, include at least 10 triangles per wavelength in a strip. This rule applies for structures such as dipoles, monopoles, and loops. Antenna Toolbox antenna meets the requirement automatically, based on the analysis frequency specified. The structured mesh generated in such cases is shown:

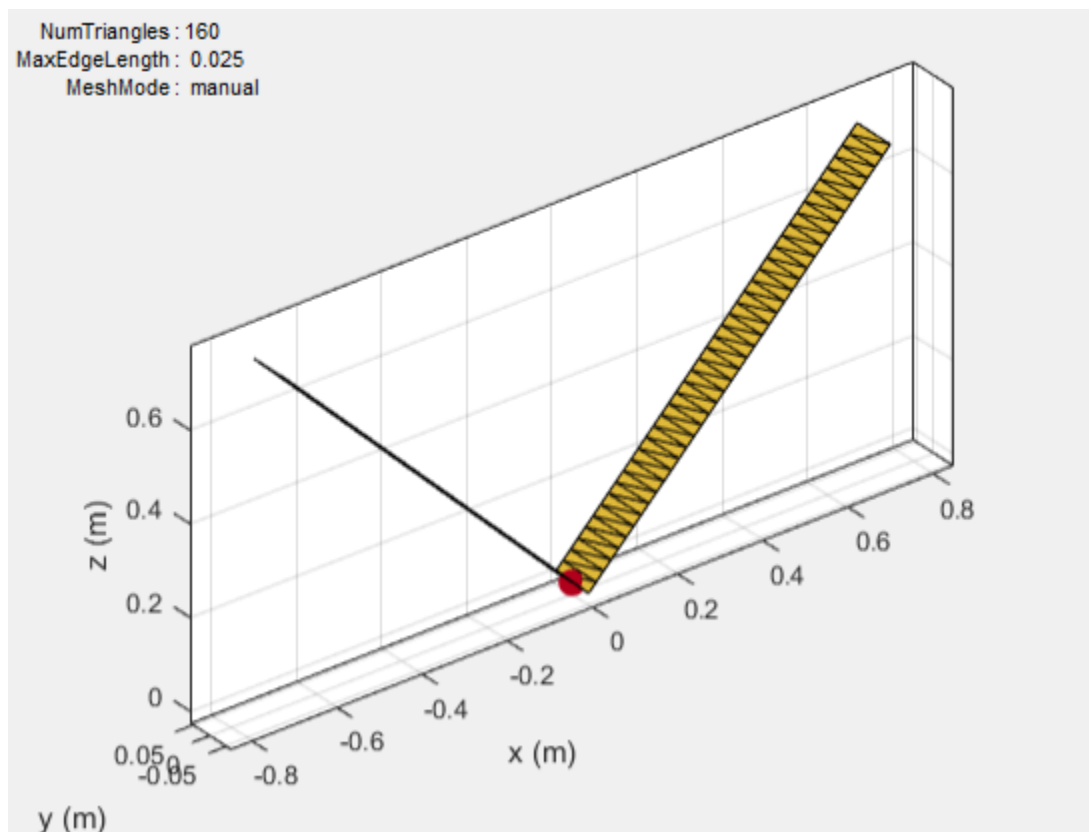

## Surface Meshing

For surface meshing, it is recommended that there be at least 100 elements per wavelength in a particular area. This rule applies to structures such as spirals, patches, and ground planes in general. Antenna Toolbox antenna meets the requirement automatically, based on the analysis frequency specified. In these cases, a non-uniform mesh is generated as shown:

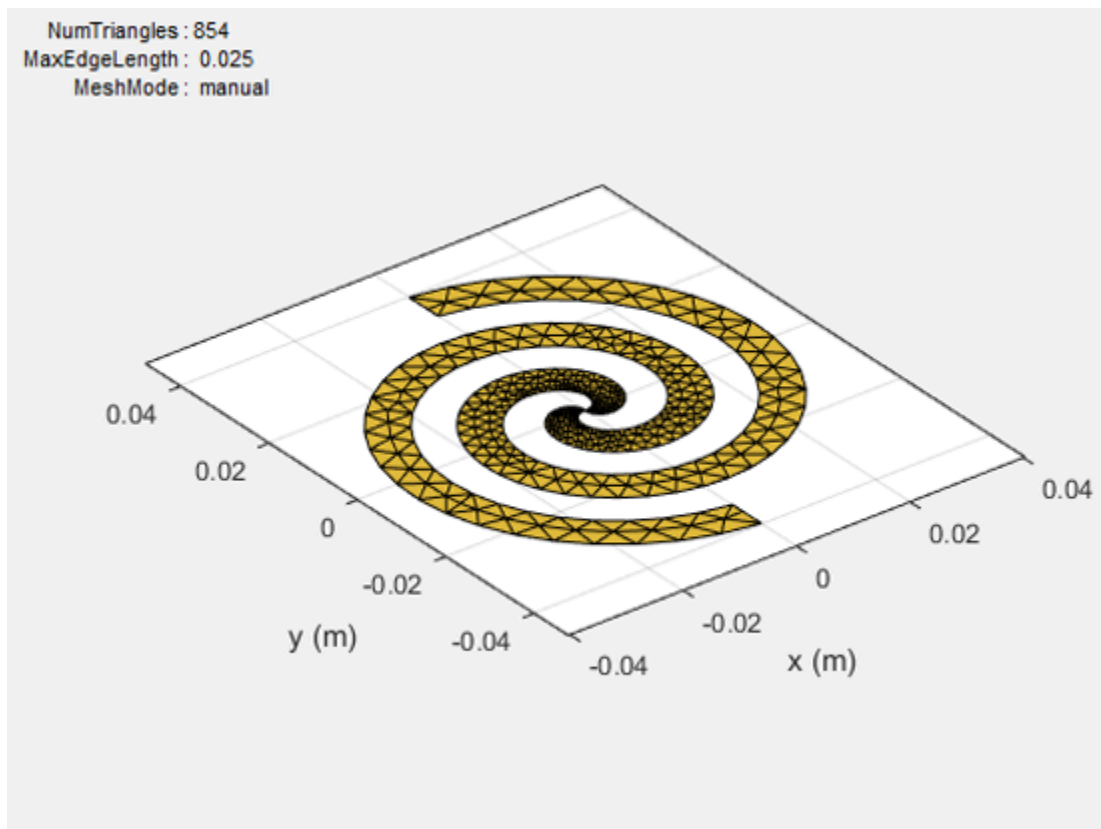

Larger number of triangles are added in regions with higher current density.

## Meshing a Dielectric Substrate

For antennas using dielectrics and metals, Antenna Toolbox uses tetrahedrons to discretize the volume of the dielectric substrate.

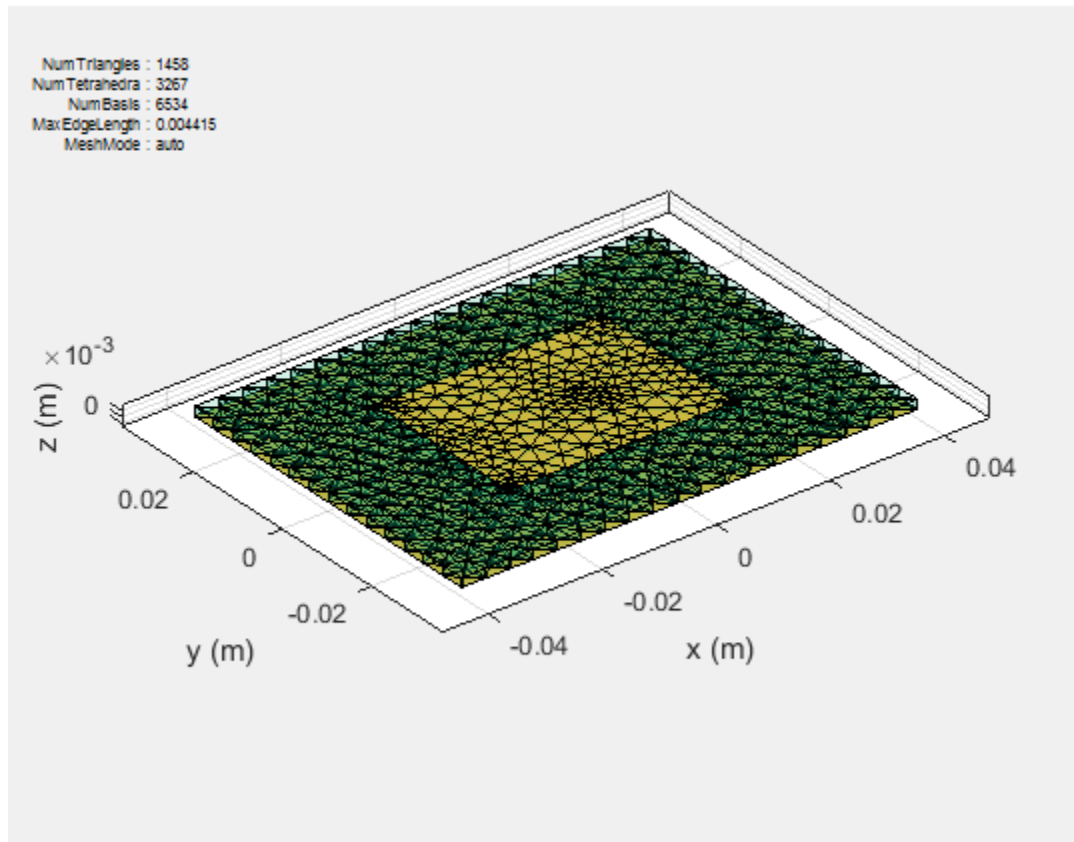

Thickness of the dielectric substrate is measured with respect to the wavelength. A dielectric substrate with thickness less than or equal to 1/50th of the wavelength is a thin substrate. When you mesh an antenna using dielectric in auto mode, thin substrates yield more accurate solutions.

A substrate with a thickness of 1/10th of the wavelength is a thick dielectric substrate. The method of moments solver requires 10 elements per wavelength to yield an accurate

solution. Manual meshing yields more accurate solutions for antennas using thick dielectric substrate, as it satisfies the 10 elements per wavelength criteria.

## References

- [1] Makarov, S.N. *Antenna and EM Modeling with MATLAB*, New York: Wiley & Sons, 2002



## Field Analysis

### In this section...

“Radiation Pattern” on page 1-27

“Beamwidth” on page 1-32

“E-Plane and H Plane” on page 1-33

“Polarization” on page 1-35

“Axial Ratio” on page 1-39

### Radiation Pattern

The *radiation pattern* of an antenna is the spatial distribution of power. The pattern displays the directivity or gain of the antenna. the *power pattern* of an antenna plots the transmitted or received power for a given radius. The *field pattern* of an antenna plots the variation in the electric or magnetic field for a given radius. The radiation pattern provides details such as the maximum and minimum value of the field quantity and the range of angles over which data is plotted.

```
h = helix;  
h.Turns = 13;  
h.Radius = 0.025;  
pattern(h,2.1e9)
```

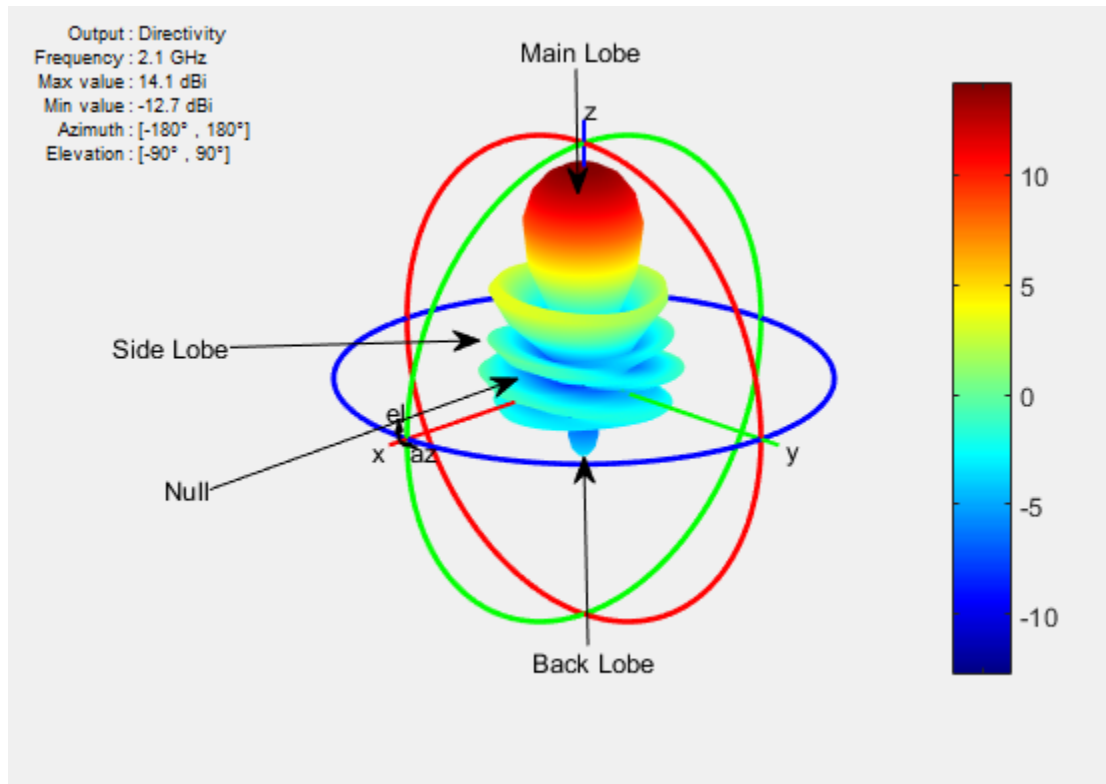

Use the `pattern` function to plot radiation pattern of any antenna in the Antenna Toolbox. By default, the function plots the directivity of the antenna. You can also plot the electric field and power pattern by using *Type* name-value pair argument of the `pattern` function.

### Lobes

Each radiation pattern of an antenna contains *radiation lobes*. The lobes are divided into *major lobes* (also called main lobes) and *minor lobes*. *Side lobes* and *back lobes* are variations of minor lobes.

```
h = helix;  
h.Turns = 13;  
h.Radius = 0.025;  
patternElevation(h,2.1e9)
```

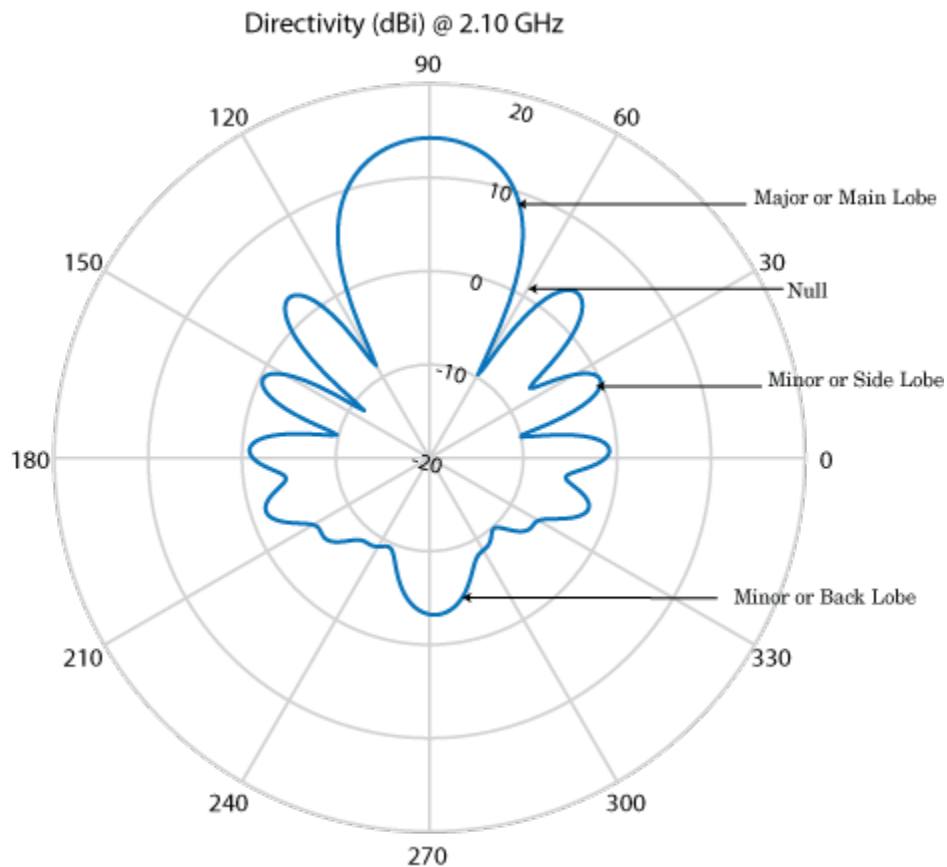

- Major or Main lobe: Shows the direction of maximum radiation, or power, of the antenna.
- Minor lobe: Shows the radiation in undesired directions of antenna. The fewer the number of minor lobes, the greater the efficiency of the antenna. *Side lobes* are minor lobes that lie next to the major lobe. *Back lobes* are minor lobes that lie opposite to the major lobe of antenna.
- Null: Shows the direction of zero radiation intensity of the antenna. Nulls usually lie between the major and minor lobe or in between the minor lobes of the antennas.

## Field Regions

For an antenna engineer and an electromagnetic compatibility (EMC) engineer, it is important to understand the regions around the antenna.

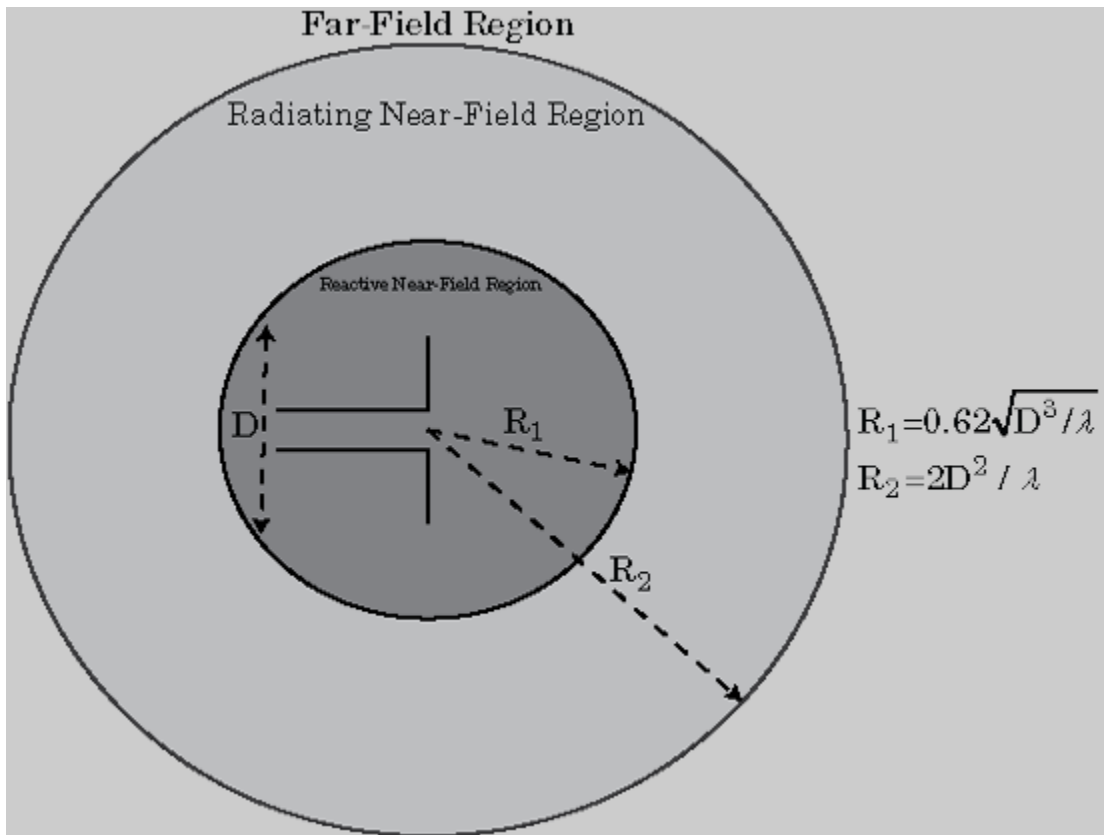

The region around an antenna is defined in many ways. The most used description is a 2- or 3-region model. The 2-region model uses the terms *near field* and the *far field* to identify specific dominant field mechanisms. The diagram is a representation of antenna fields and boundaries. The 3-field region splits the near field into a transition zone, where a weakly radiative mechanism is at work.

**Near-Field Region:** The *near-field region* is divided into two transition zones: a reactive zone and radiating zone.

- **Reactive Near-Field Region:** This region is closest to the antenna surface. The reactive field dominates this region. The reactive field is stored energy, or standing waves. The fields in this region change rapidly with distance from the antenna. The equation for outer boundary of this region is:  $R < 0.62\sqrt{D^3/\lambda}$  where  $R$  is the distance from the antenna,  $\lambda$  is the wavelength, and  $D$  is the largest dimension of the antenna. This equation holds true for most antennas. In a very short dipole, the outer boundary of this region is  $\lambda/2\pi$  from the antenna surface.
- **Radiating Near-Field Region:** This region is also called the *Fresnel region* and lies between the reactive near-field region and the far-field region. The existence of this region depends on the largest dimension of the antenna and the wavelength of operation. The radiating fields are dominant in this region. The equation for the inner boundary of the region is equation  $R \geq 0.62\sqrt{D^3/\lambda}$  and the outer boundary is  $R < 2D^2/\lambda$ . This holds true for most antennas. The field distribution depends on the distance from the antenna.

**Far-field Region:** This region is also called *Fraunhofer region*. In this region, the field distribution does not depend on the distance from the antenna. The electric and magnetic fields in this region are orthogonal to each other. This region contains propagating waves. The equation for the inner boundary of the far-field is  $R = 2D^2/\lambda$  and the equation for the outer boundary is infinity.

### Directivity and Gain

*Directivity* is the ability of an antenna to radiate power in a particular direction. It can be defined as ratio of maximum radiation intensity in the desired direction to the average radiation intensity in all other directions. The equation for directivity is:

$$D = \frac{4\pi U(\theta, \phi)}{P_{rad}}$$

where:

- $D$  is the directivity of the antenna
- $U$  is the radiation intensity of the antenna
- $P_{rad}$  is the average radiated power of antenna in all other directions

Antenna directivity is dimensionless and is calculated in decibels compared to the isotropic radiator (dBi).

The *gain* of an antenna depends on the directivity and efficiency of the antenna. It can be defined as the ratio of maximum radiation intensity in the desired direction to the total power input of the antenna. The equation for gain of an antenna is:

$$G = \frac{4\pi U(\theta, \phi)}{P_{in}}$$

where:

- $G$  is the gain of the antenna
- $U$  is the radiation intensity of the antenna
- $P_{in}$  is the total power input to the antenna

If the efficiency of the antenna in the desired direction is 100%, then the total power input to the antenna is equal to the total power radiated by the antenna, that is,  $P_{in} = P_{rad}$ . In this case, the antenna directivity is equal to the antenna gain.

## Beamwidth

*Antenna beamwidth* is the angular measure of the antenna pattern coverage. As seen in the figure, the main beam is a region around maximum radiation. This beam is also called the major lobe, or main lobe of the antenna.

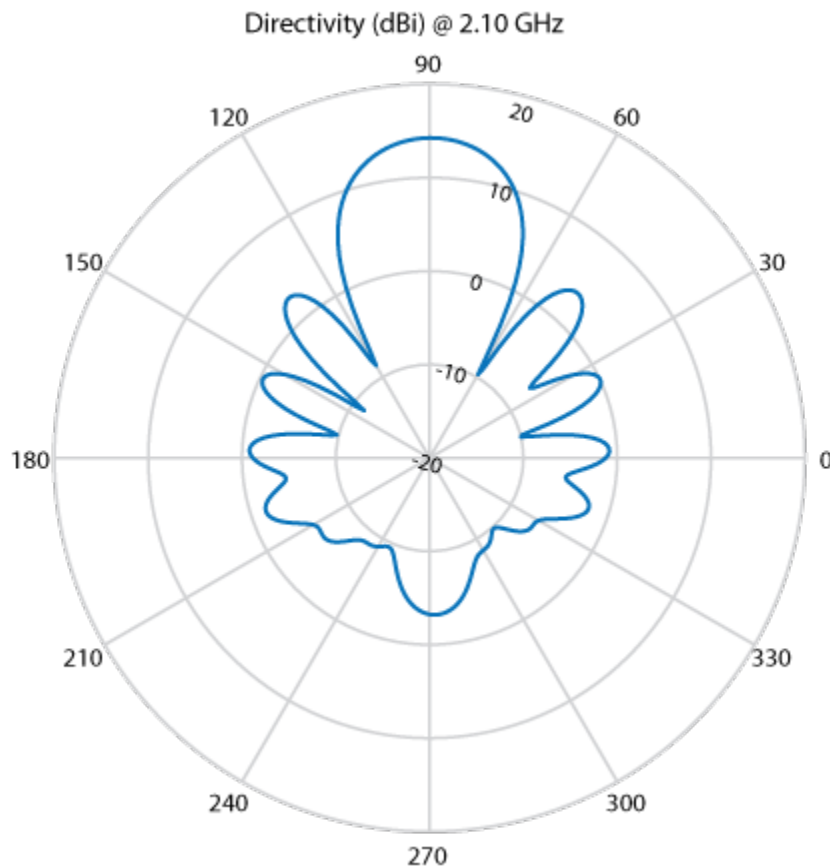

*Half power beamwidth* (HPBW) is the angular separation in which the magnitude of the radiation pattern decreases by 50% (or  $-3\text{dB}$ ) from the peak of the main beam

Use the `beamwidth` function to calculate the beamwidth of any antenna in Antenna Toolbox.

## E-Plane and H Plane

**E-plane:** Plane containing the electric field vector and the direction of maximum radiation. Consider a dipole antenna that is vertical along the  $z$ -axis. Use the `patternElevation` function to plot the elevation plane pattern. The elevation plane pattern shown captures the E-plane behavior of the dipole antenna.

```
d = dipole;  
patternElevation(d,70e6)
```

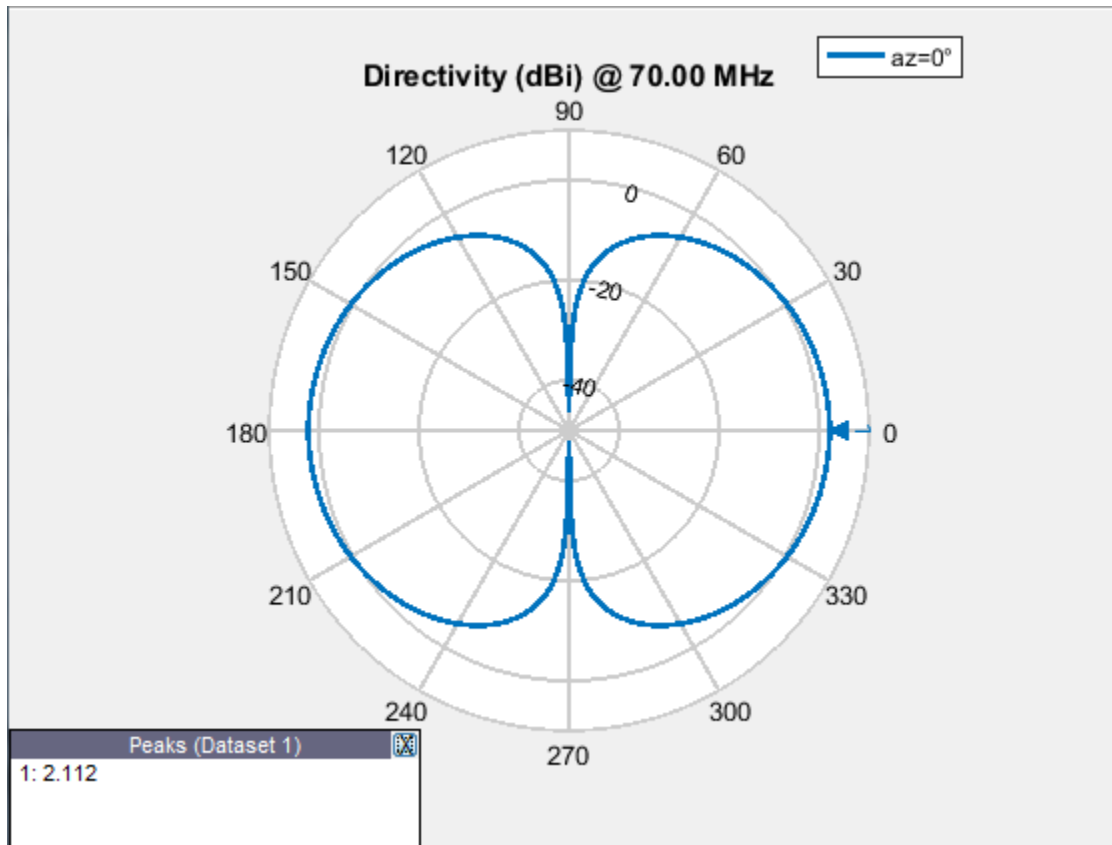

H-plane: Plane containing the magnetic field vector and the direction of maximum radiation. Use the `patternAzimuth` function to plot the azimuth plane pattern of a dipole antenna. The azimuthal variation in pattern shown captures the H-plane behavior of the dipole antenna.

```
d = dipole;  
patternAzimuth(d,70e6)
```



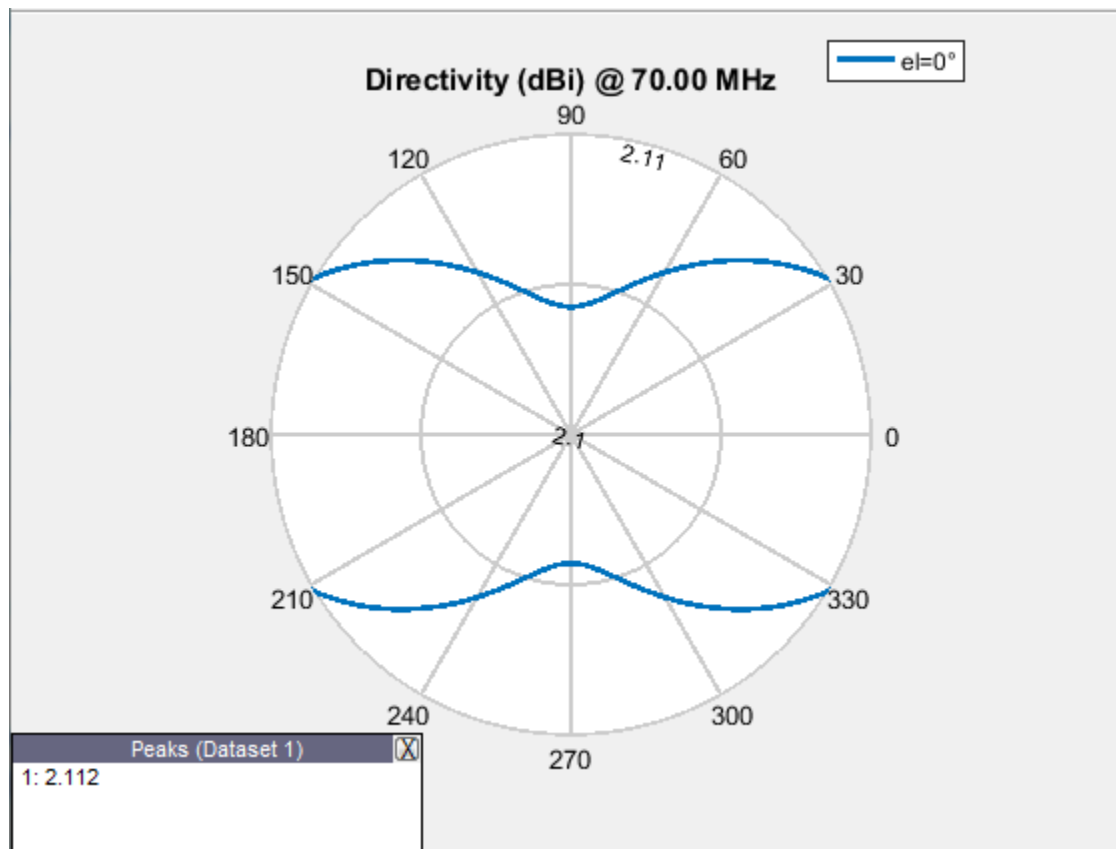

Use `EHfields` to measure the electric and magnetic fields of the antenna. The function can be used to calculate both near and far fields.

## Polarization

*Polarization* is the orientation of the electric field, or E-field, of an antenna. Polarization is classified as elliptical, linear, or circular.

**Elliptical polarization:** If the electric field remains constant along the length but traces an ellipse as it moves forward, the field is elliptically polarized. Linear and circular polarizations are special cases of elliptical polarization.

**Linear polarization:** If the electric field vector at a point in space is directed along a straight line, the field is linearly polarized. A linearly polarized antenna radiates only one plane and this plane contains the direction of propagation of the radio waves. There are two types of linear polarization:

- **Horizontal Polarization:** The electric field vector is parallel to the ground plane. To view the horizontal polarization pattern of an antenna, use the `pattern` function, with the 'Polarization' name-value pair argument set to 'H'. The plot shows the horizontal polarization pattern of a dipole antenna:

```
d = dipole;  
pattern(d,70e6, 'Polarization', 'H')
```

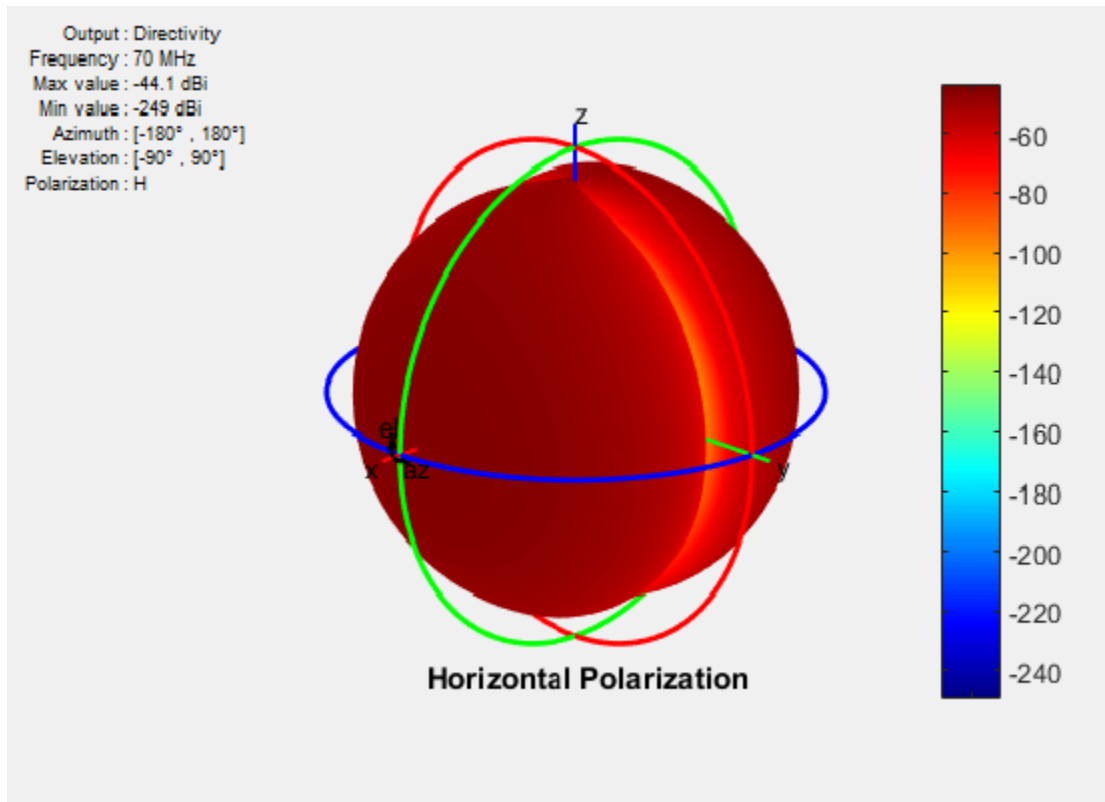

USA television networks use horizontally polarized antennas for broadcasting.

- **Vertical Polarization:** The electric field vector is perpendicular to the ground plane. To view the vertical polarization pattern of an antenna, use the `pattern` function, with the 'Polarization' name-value pair argument set to 'V'. Vertical polarization is used when a signal has to be radiated in all directions. The plot shows the vertical polarization pattern of a dipole antenna:

```
d = dipole;
pattern(d,70e6, 'Polarization', 'V')
```

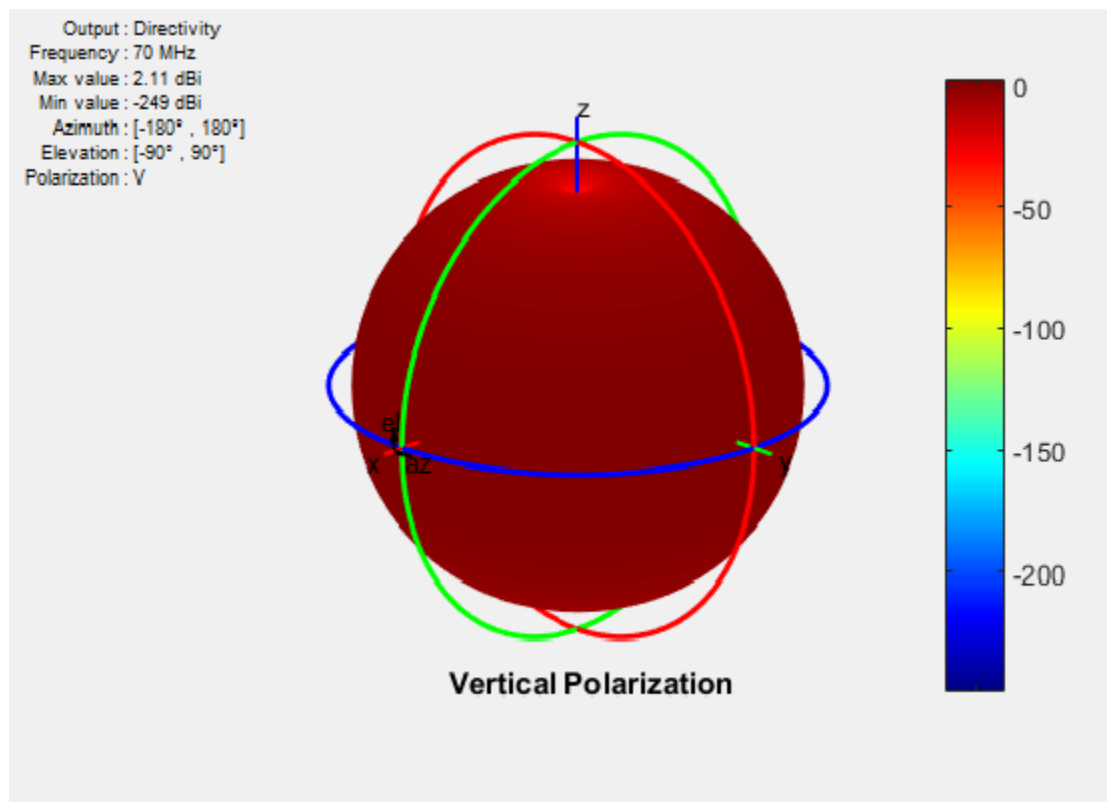

An AM radio broadcast antenna or an automobile whip antenna are some examples of vertically polarized antennas.

**Circular Polarization:** If the electric field remains constant along the straight line but traces circle as it moves forward, the field is circularly polarized. This wave radiates

in both vertical and horizontal planes. Circular polarization is most often used in satellite communications. There are two types of circular polarization:

- **Right-Hand Circularly Polarized (RHCP):** The electric field vector is traced in the counterclockwise direction. To view the RHCP pattern of an antenna, use the `pattern` function, with the 'Polarization' name-value pair argument set to 'RHCP'. The plot shows RHCP pattern of helix antenna:

```
h = helix;  
h.Turns = 13;  
h.Radius = 0.025;  
pattern(h,1.8e9,'Polarization','RHCP')
```

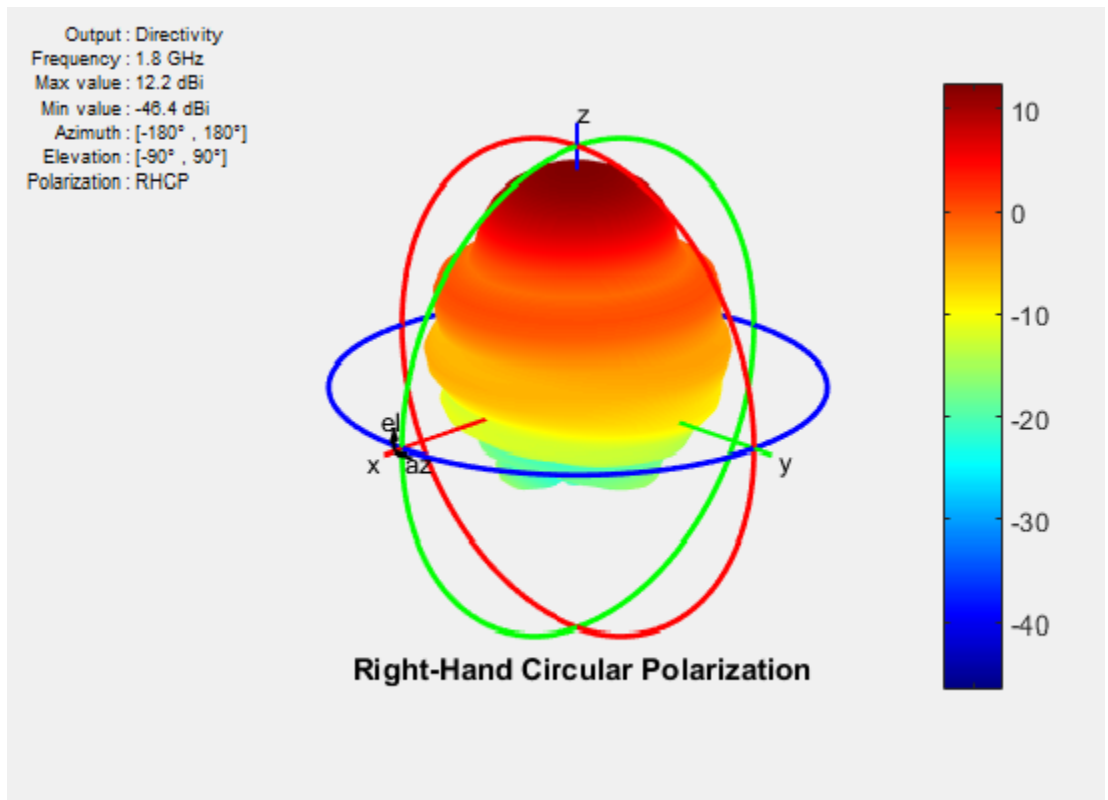

- **Left-Hand circularly polarized (LHCP):** The electric field vector is traced in the clockwise direction. To view the LHCP pattern of an antenna, use the `pattern`

function, with the 'Polarization' name-value pair argument set to 'LHCP'. The plot shows LHCP pattern of helix antenna:

```
h = helix;
h.Turns = 13;
h.Radius = 0.025;
pattern(h,1.8e9, 'Polarization', 'LHCP')
```

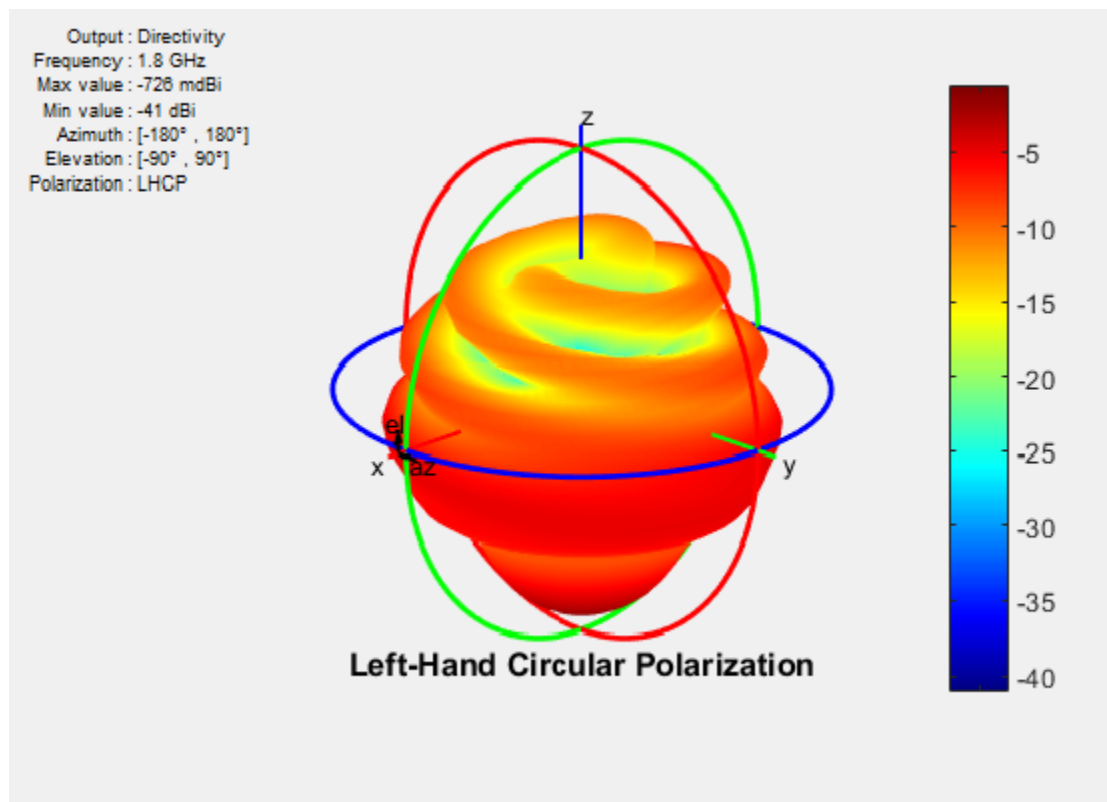

For efficient communications, the antennas at the transmitting and receiving end must have same polarization.

## Axial Ratio

*Axial ratio* (AR) of an antenna in a given direction quantifies the ratio of orthogonal field components radiated in a circularly polarized wave. An axial ratio of infinity implies a

linearly polarized wave. When the axial ratio is 1, the radiated wave has pure circular polarization. Values greater than 1 imply elliptically polarized waves.

Use `axialRatio` to calculate the axial ratio for any antenna in the Antenna Toolbox.

## References

- [1] Balanis, C.A. *Antenna Theory. Analysis and Design*, 3rd Ed. New York: Wiley, 2005.
- [2] Stutzman, Warren.L and Thiele, Gary A. *Antenna Theory and Design*, 3rd Ed. New York: Wiley, 2013.
- [3] Capps, C. *Near Field or Far Field*, EDN, August 16, 2001, pp.95 - pp.102.

## Rotate Antenna and Arrays

### In this section...

“Rotate Single Antenna Element” on page 1-41

“Rotate Single Antenna Element About Multiple Axis” on page 1-44

“Rotate Dipole Backed Reflector” on page 1-45

“Rotate Antenna Array Elements” on page 1-48

To rotate antenna elements in Antenna Toolbox, use the `Tilt` and `TiltAxis` property. The `Tilt` property is a scalar or a vector and specifies the angle of rotation of the antenna in degrees. The `TiltAxis` property is a vector and specifies the axis of rotation ( $x$ ,  $y$ ,  $z$ ) of the antenna. Antenna arrays do not have these properties and cannot be rotated.

### Rotate Single Antenna Element

Create a patch antenna. By default, this antenna is on the XY plane.

```
patch = patchMicrostrip;  
show(patch)
```

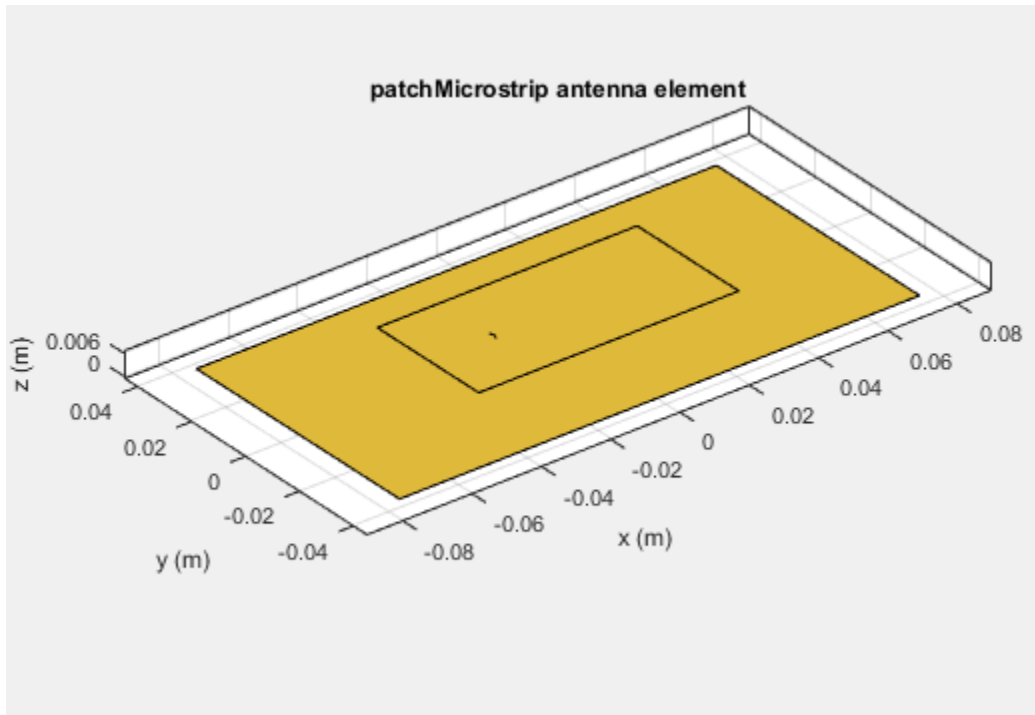

To make the antenna lie on the Y-Z plane, rotate it by 90 degrees about the Y-axis. The rotation follows the standard right-hand rule.

```
patch.TiltAxis = 'Y';  
patch.Tilt = 90;  
show(patch)
```



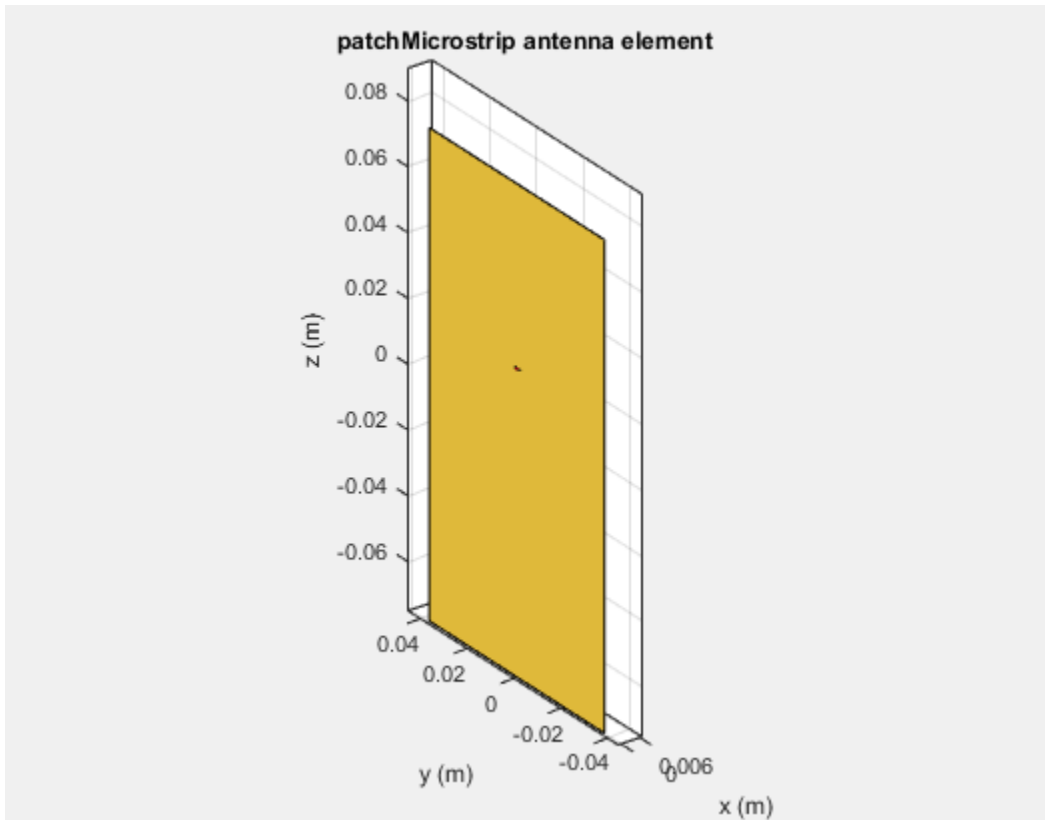

The patch lies behind the ground plane and is not visible. To make the patch visible (in front of the ground plane), rotate the antenna about the negative y-axis.

```
patch.TiltAxis = [0 -1 0];  
show(patch)
```

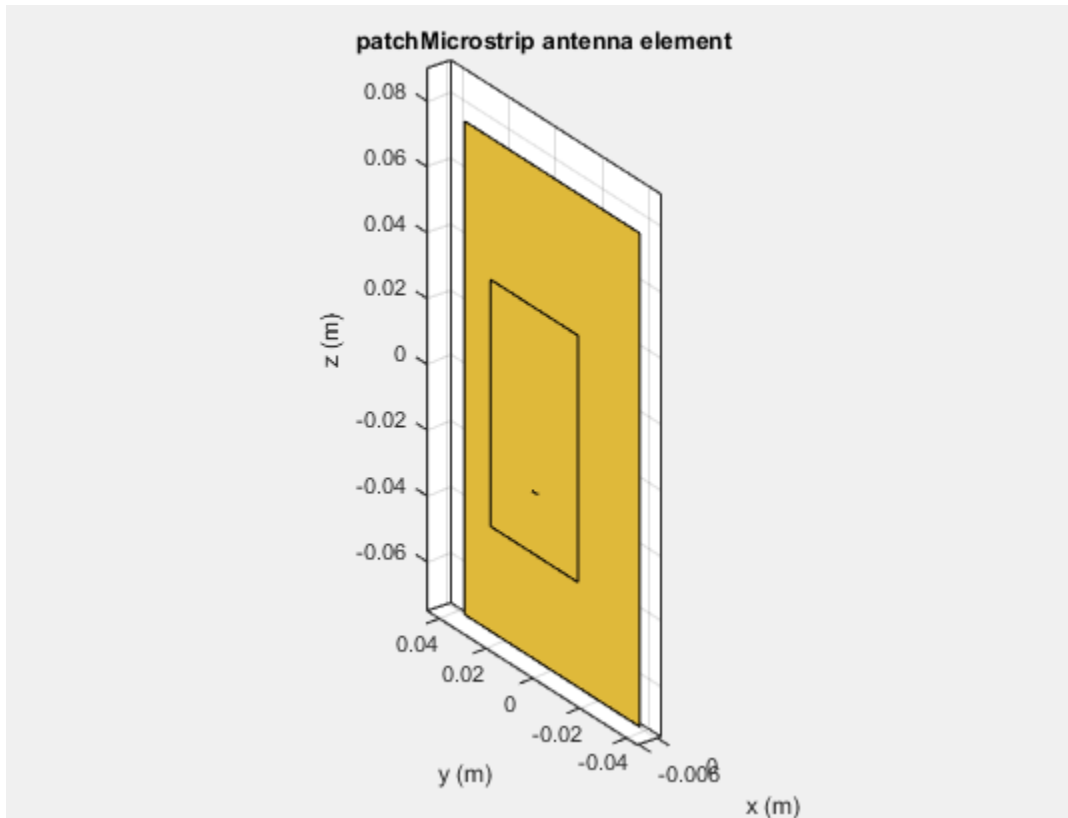

## Rotate Single Antenna Element About Multiple Axis

Create a dipole antenna rotated at 90 degrees about two three-element vector points in space.

```
d = dipole('Tilt',[90 90],'TiltAxis', [0 1 0; 0 1 1])
```

dipole with properties:

```
Length: 2
Width: 0.1000
FeedOffset: 0
Tilt: [90 90]
TiltAxis: [2x3 double]
```

```
show(d)
```

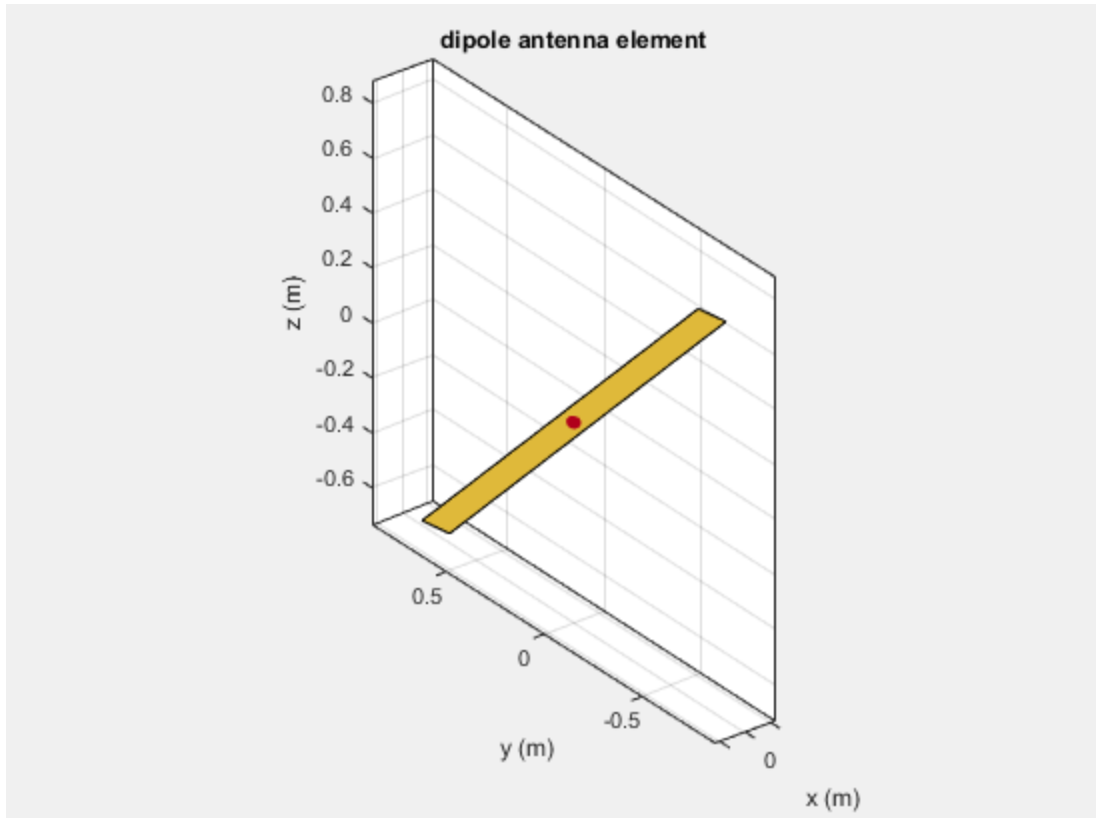

## Rotate Dipole Backed Reflector

The `Tilt` and `TiltAxis` properties are available for dipole and reflector elements. Use these properties if you want to model the antenna parallel or perpendicular to the ground plane.

Create a reflector element. By default, the dipole is parallel to the reflector element.

```
r = reflector;  
show(r)
```

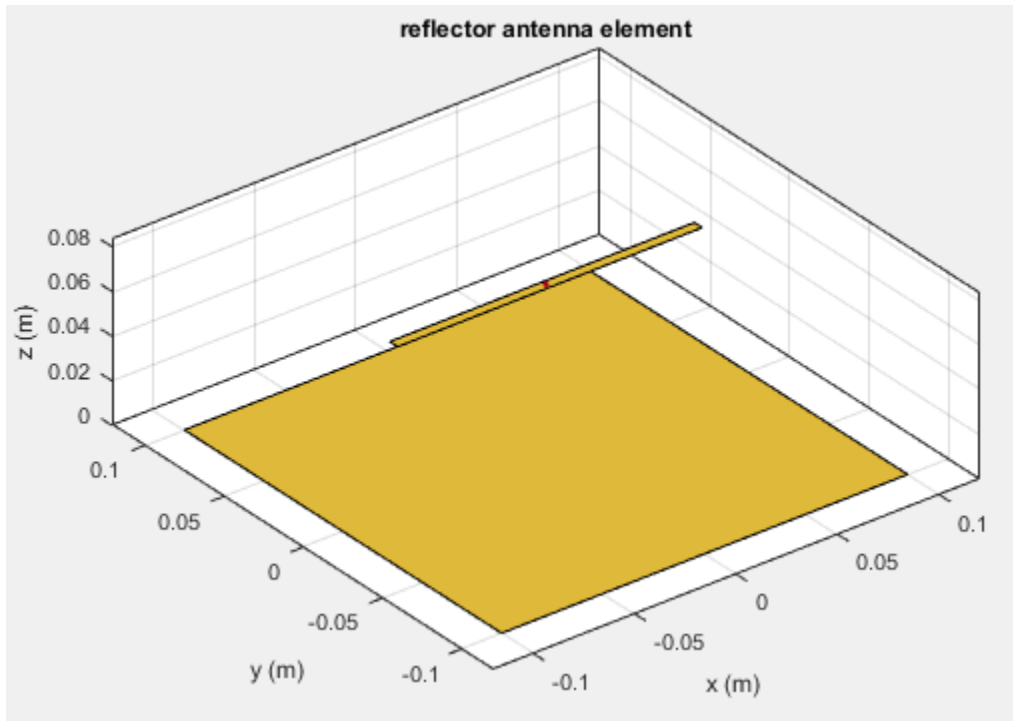

The dipole is the exciter element of the reflector. View its properties.

```
r.Exciter;
```

```
dipole with properties:
```

```
    Length: 0.1500  
    Width: 0.0050  
FeedOffset: 0  
    Tilt: 90  
TiltAxis: [0 1 0]
```

In the properties, you see that the dipole element is already rotated by 90 degrees about the y-axis and is parallel to the X-Y plane. To make the dipole perpendicular to the X-Y plane, change the tilt of the dipole to zero degrees.

```
r.Exciter.Tilt = 0;  
show (r)
```

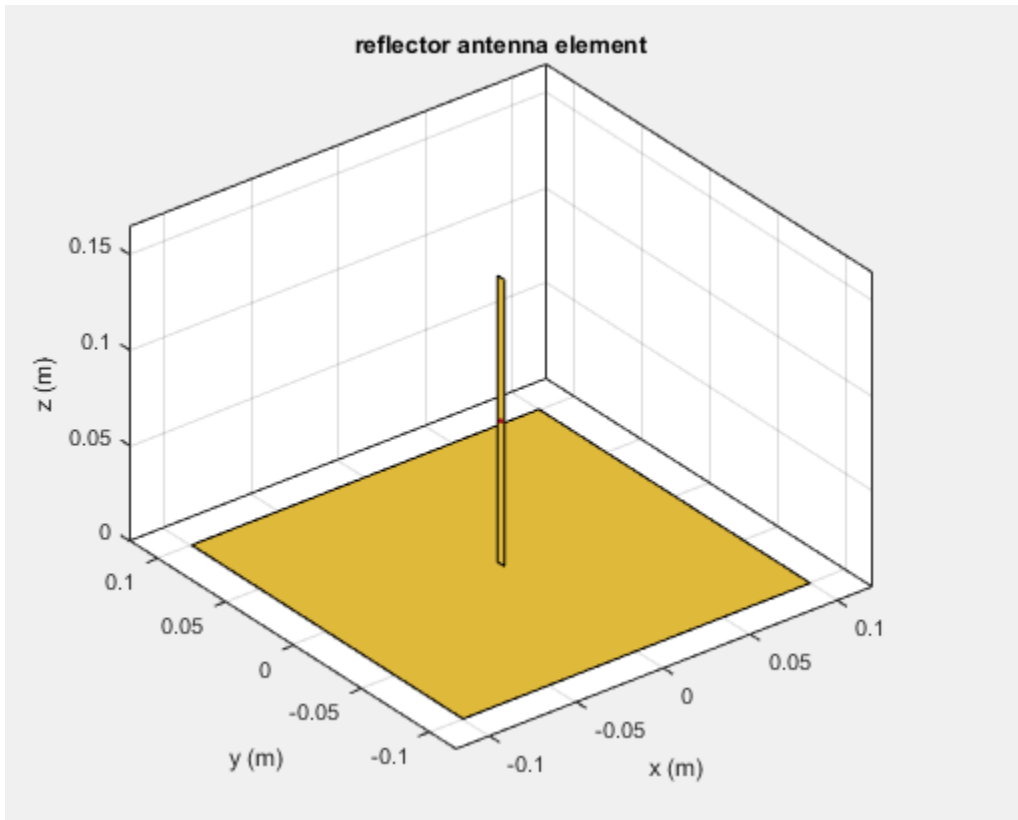

Rotating the reflector element rotates the entire structure by the specified angle. To rotate the complete antenna, you use the *Tilt* property. For example, rotate the reflector by 90 degrees about the y-axis. According to the right-hand rule, the reflector now lies in the Y-Z plane with the dipole.

```
r = reflector;  
r.Tilt = 90;  
show(r)
```

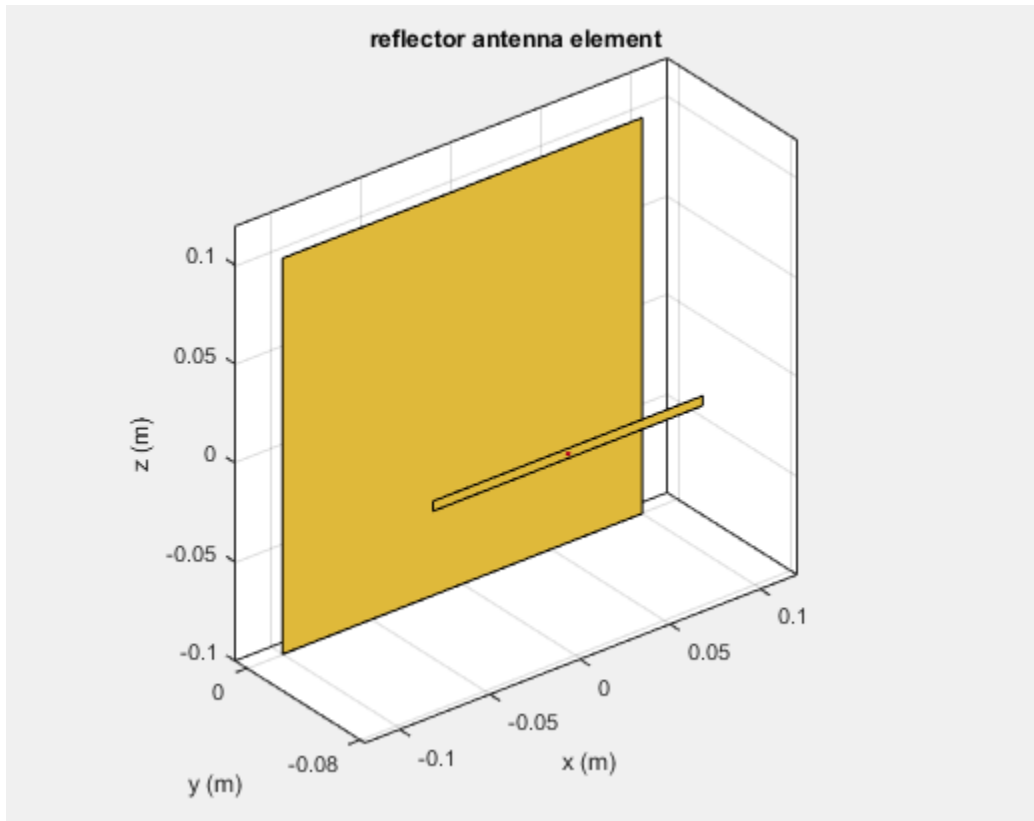

## Rotate Antenna Array Elements

The Tilt and TiltAxis properties are available for antenna array elements.

Create an array of Archimedean spirals with each spiral rotated at 30 degrees about the x-axis and y-axis. First create one spiral antenna.

```
s = spiralArchimedean;  
l = linearArray('Element',s,'ElementSpacing',0.1,...  
'NumElements',3,'Tilt',30,'TiltAxis',[1 1 0]);  
show(l)
```

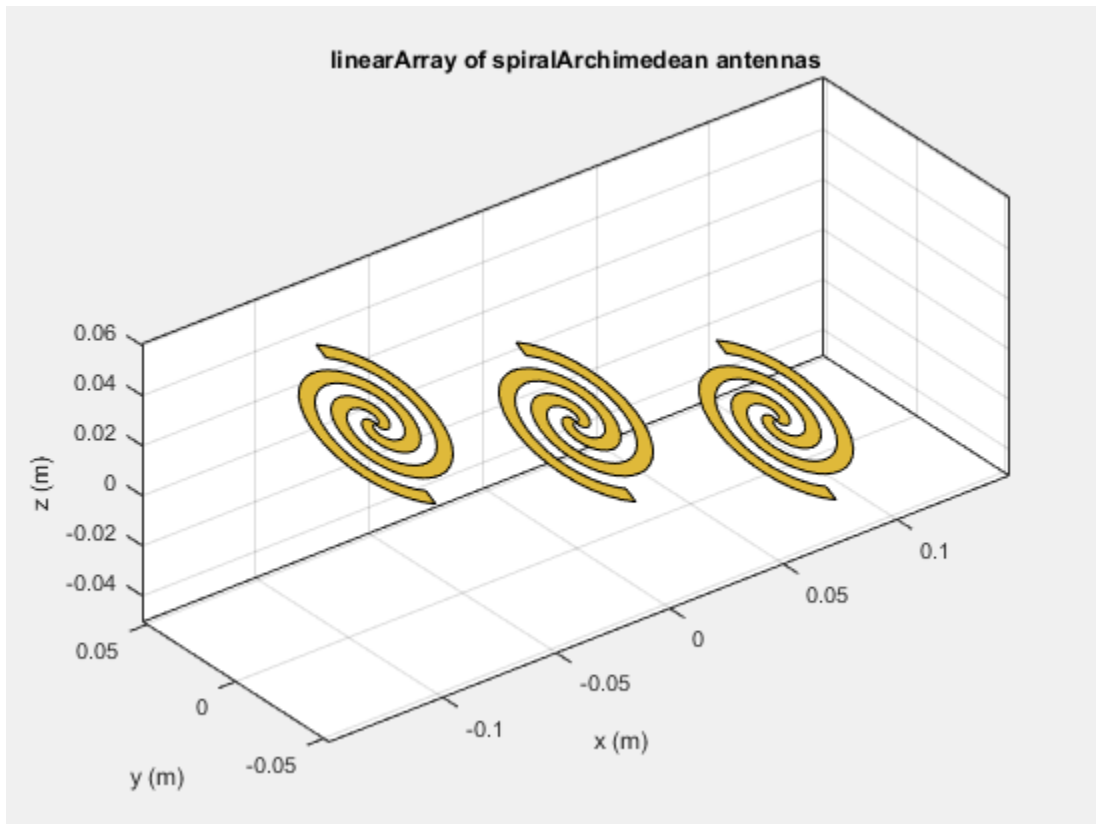

## See Also

### More About

- "Antenna Classification"

## Infinite Ground Plane

**In this section...**

“Image Theory” on page 1-50

“Formulate the Image Theory Technique” on page 1-51

Antenna Toolbox library element uses the image theory technique to model an infinite ground plane. The main advantage of image theory technique is that you do not need to discretize the ground plane. Image theory reduces the overall size of the problem and you get a solution faster.

### Image Theory

The image theory technique uses a catalog of electromagnetic problems that produce identical field distributions. You can identify these electromagnetic problems by noting that conducting surfaces are of constant potential. Placing these conducting surfaces along any equipotential lines in any field distributions does not alter the fields.

Consider a positive and negative charge placed a distance of  $2x$  apart from each other. The equipotential surface for these two charges forms at a distance midway between them.

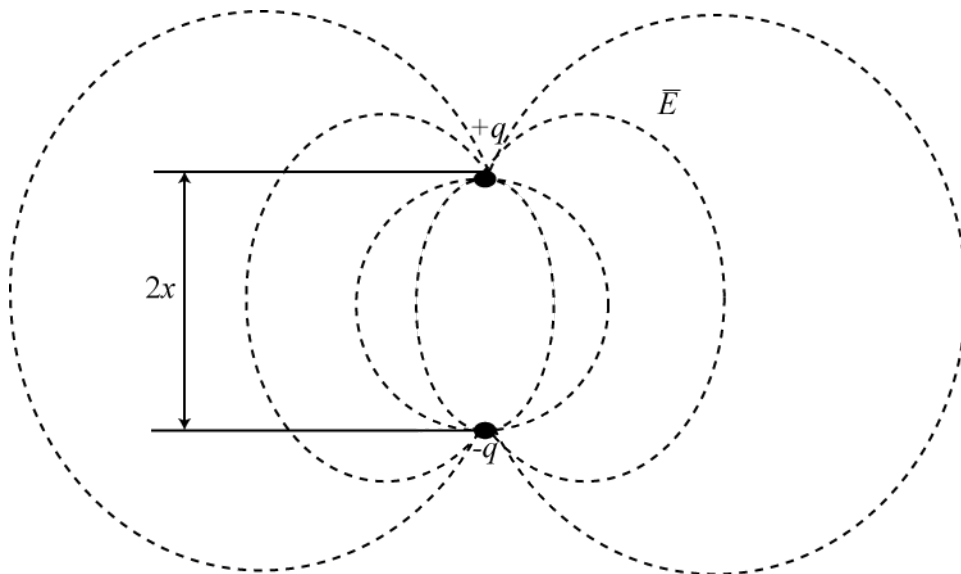



If you place a conducting object along this equipotential surface, then the field above the surface does not change.

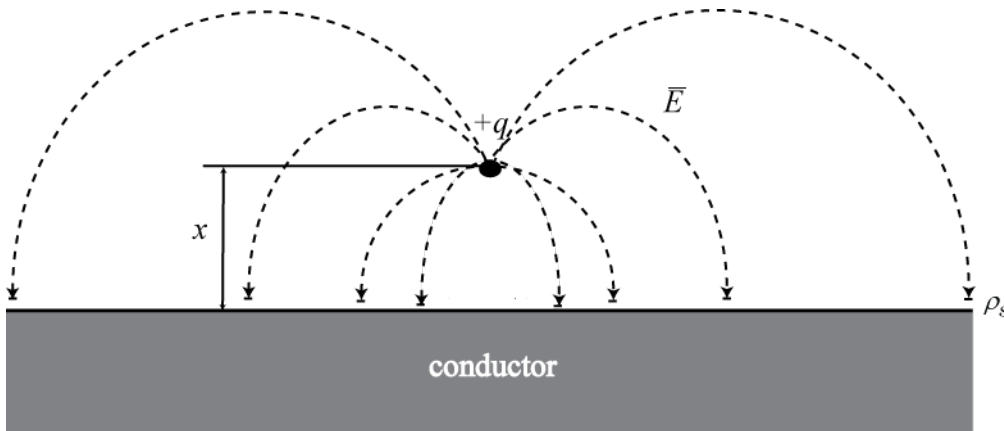

You can also apply this equivalence in reverse. Consider charges that are distance  $x$  apart from a conducting surface. You can replace the conducting surface with a set of image charges whose signs are opposite those of the original charge. Place these image charges at a distance  $x$  below the original conducting surface. This method eliminates the conducting plate, leaving only charges in unbound space. This equivalence is called the *method of images*.

### Formulate the Image Theory Technique

Consider a rectangular plate over an infinite ground plane. This rectangular plate is divided into a triangular mesh. The induced currents flow over the triangulated surface using the RWG basis functions.

Original Problem:

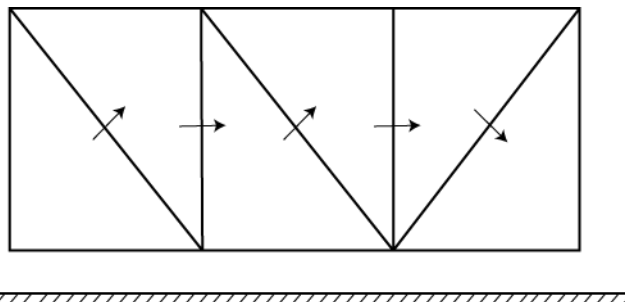

You formulate the problem by considering real and image basis functions. You can show the same problem using image theory or method of images. The interaction matrix is calculated using the interaction between real and image basis functions.

Equivalent Problem:

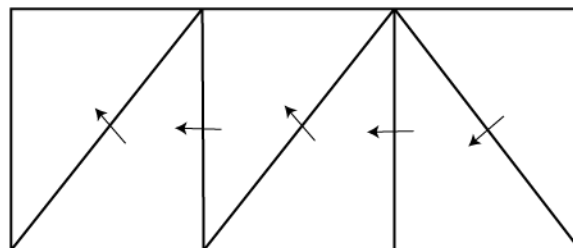
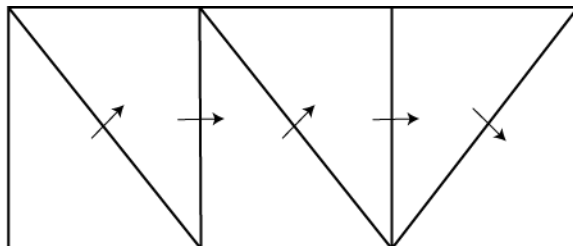

According to the method of images, the real and image electric currents are equal to each other in terms of magnitude. The parallel components are in opposite direction. The normal components are in the same direction.

Original Problem:

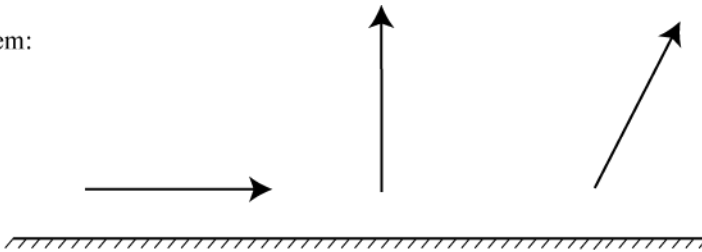

Equivalent Problem:

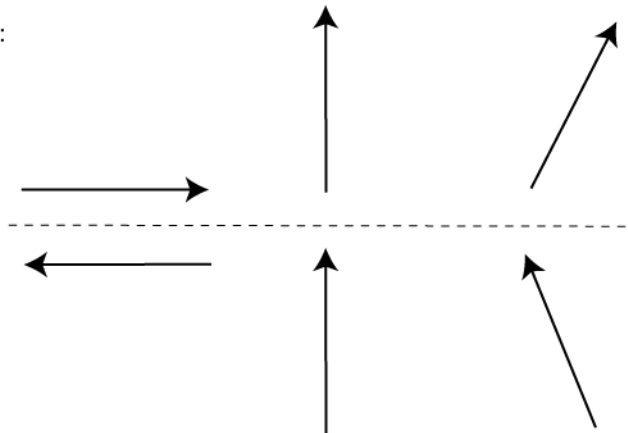

## References

- [1] Balanis, C.A. *Antenna Theory. Analysis and Design*, 3rd Ed. New York: Wiley, 2005.
- [2] Yildirim, Cemal. "Scattering and Radiation problems of arbitrary shaped conducting bodies above ground plane" Ph.D. Thesis. Bilkent University, Ankara, Turkey, October, 2002

## **See Also**

### **More About**

- “Method of Moments Solver for Metal Structures” on page 3-2

## Model Infinite Ground Plane for Balanced Antennas

This example shows how to model an infinite ground plane and calculate fundamental antenna parameters for balanced antennas.

### Create Antenna On Infinite Ground Plane

Create a reflector antenna on a ground plane of infinite length.

```
r = reflector ('GroundPlaneLength', inf)
r =
  reflector with properties:
        Exciter: [1x1 dipole]
        Substrate: [1x1 dielectric]
  GroundPlaneLength: Inf
  GroundPlaneWidth: 0.2000
        Spacing: 0.0750
  EnableProbeFeed: 0
        Tilt: 0
        TiltAxis: [1 0 0]
        Load: [1x1 lumpedElement]
```

### View Antenna Geometry

View the physical construction of infinite ground plane reflector antenna.

```
figure;show(r);
```

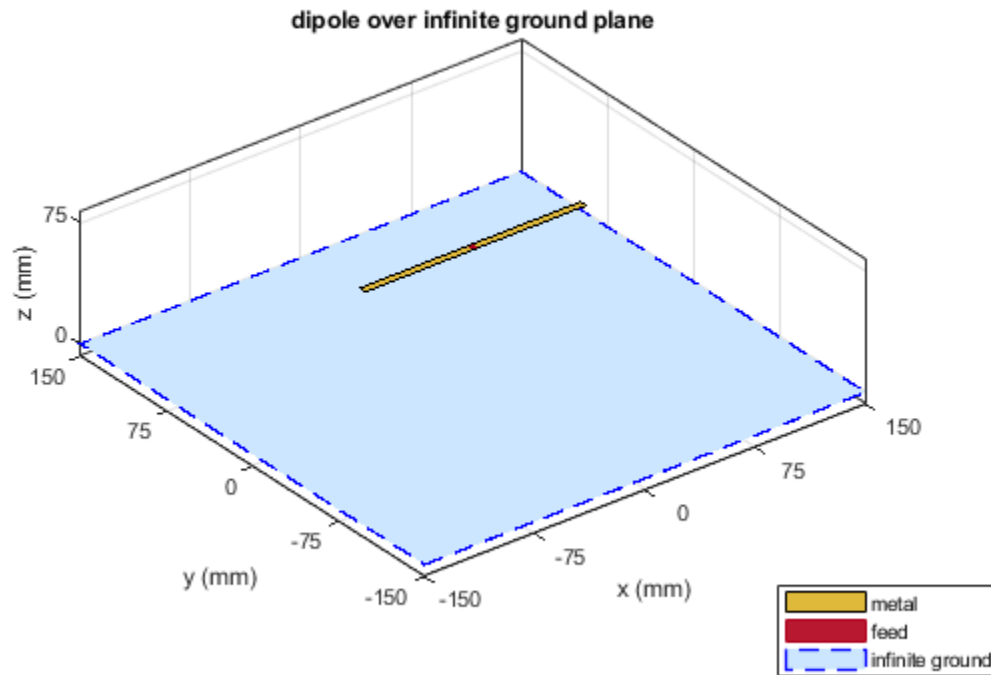

### Calculate Impedance of Antenna

Calculate the impedance of reflector antenna over a frequency range of 800MHz to 1GHz.

```
figure;impedance(r,800e6:5e6:1e9);
```

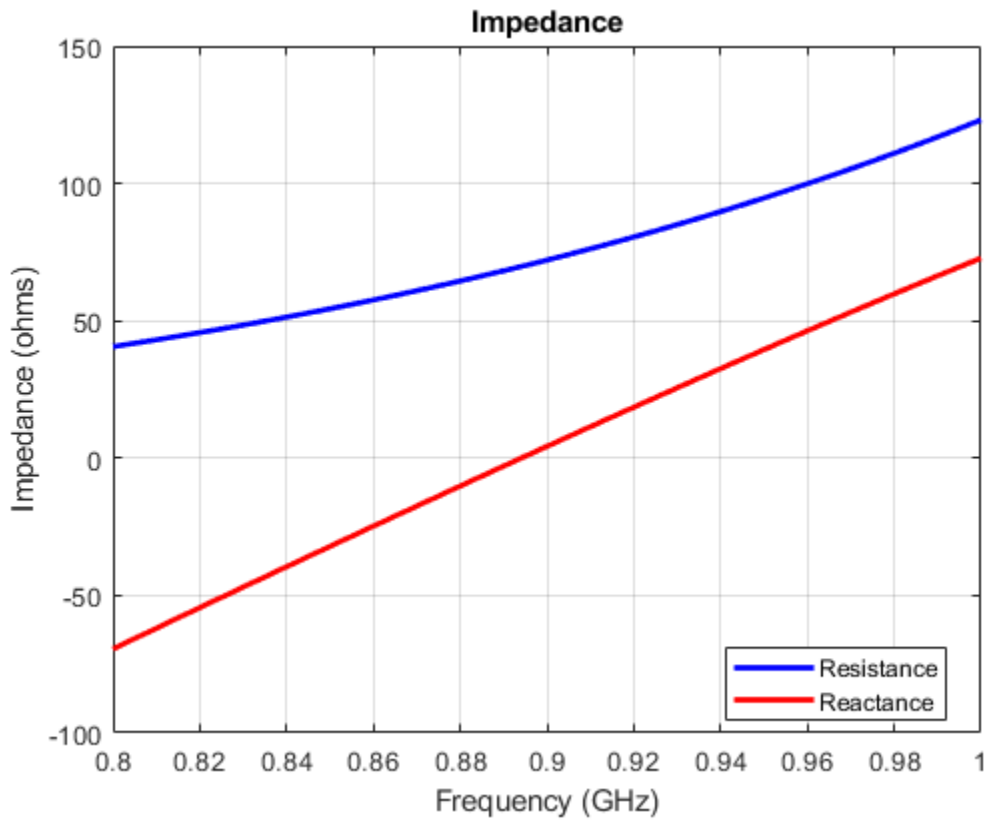

### Plot Radiation Pattern of Antenna

Plot the radiation pattern of reflector antenna at a frequency of 900MHz.

```
figure;pattern(r,900e6);
```

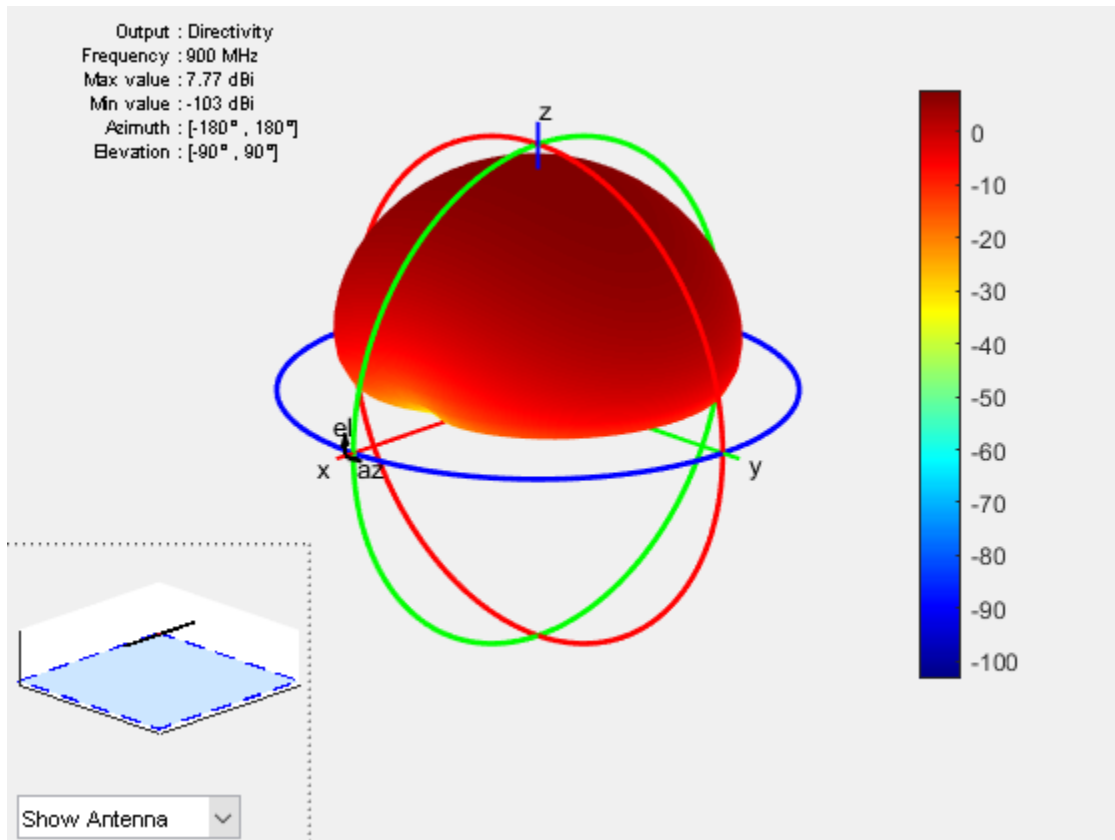

### Visualize Antenna Mesh

Mesh and view the infinite ground plane reflector antenna.

```
figure; mesh(r);
```



NumTriangles : 40  
NumTetrahedra : 0  
NumBasis : 39  
MaxEdgeLength : 0.008328  
MeshMode : auto

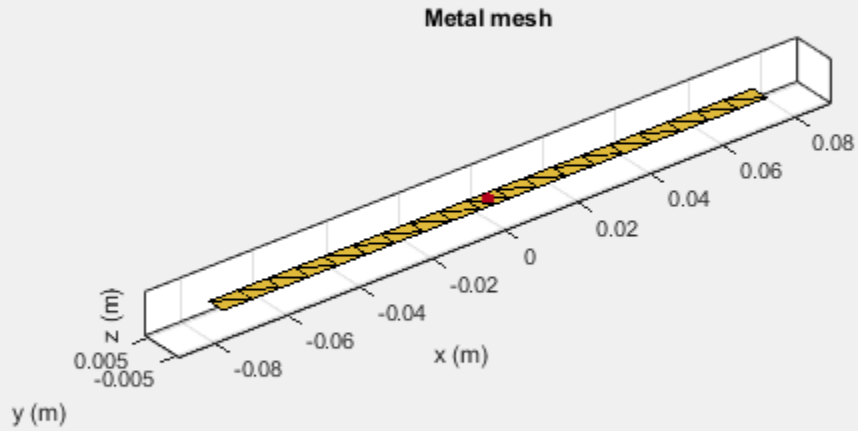

## Model Infinite Ground Plane for Unbalanced Antennas

This example shows how to model an infinite ground plane and calculate fundamental antenna parameters for unbalanced antennas.

### Create Antenna on Infinite Ground Plane

Create a patch microstrip antenna on a ground plane of infinite length.

```
p = patchMicrostrip('GroundPlaneLength', inf)
```

```
p =  
patchMicrostrip with properties:  
  
        Length: 0.0750  
        Width: 0.0375  
        Height: 0.0060  
        Substrate: [1x1 dielectric]  
GroundPlaneLength: Inf  
GroundPlaneWidth: 0.0750  
PatchCenterOffset: [0 0]  
        FeedOffset: [-0.0187 0]  
        Tilt: 0  
        TiltAxis: [1 0 0]  
        Load: [1x1 lumpedElement]
```

### View Antenna Geometry

View the physical construction of the patch microstrip antenna using infinite ground plane.

```
figure;  
show(p);
```

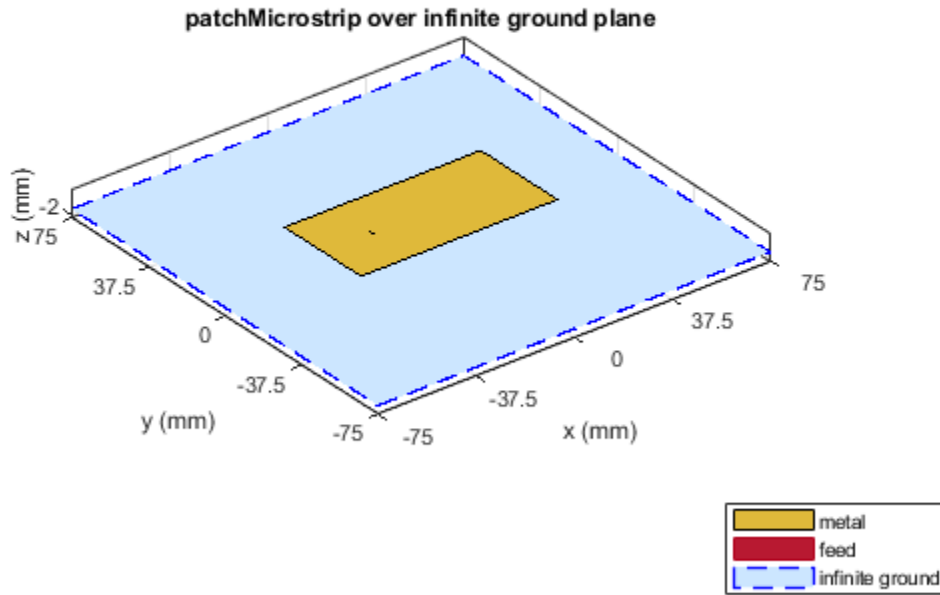

### Calculate Impedance of Antenna

Calculate the impedance of the antenna over a frequency range of 1.60 GHz to 1.70 GHz.

```
figure;
impedance(p,1.60e9:5e6:1.70e9);
```

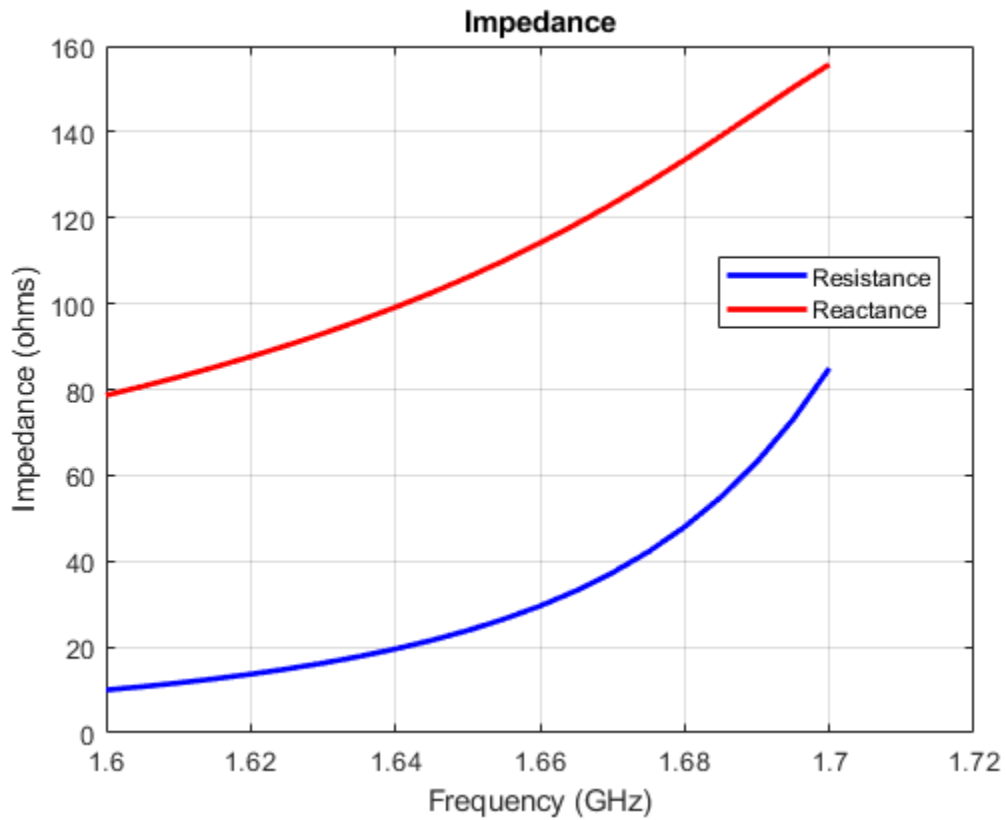

### Plot Radiation Pattern of Antenna

Plot the radiation pattern of the antenna at a frequency of 1.67 GHz.

```
figure;  
pattern(p,1.67e9);
```

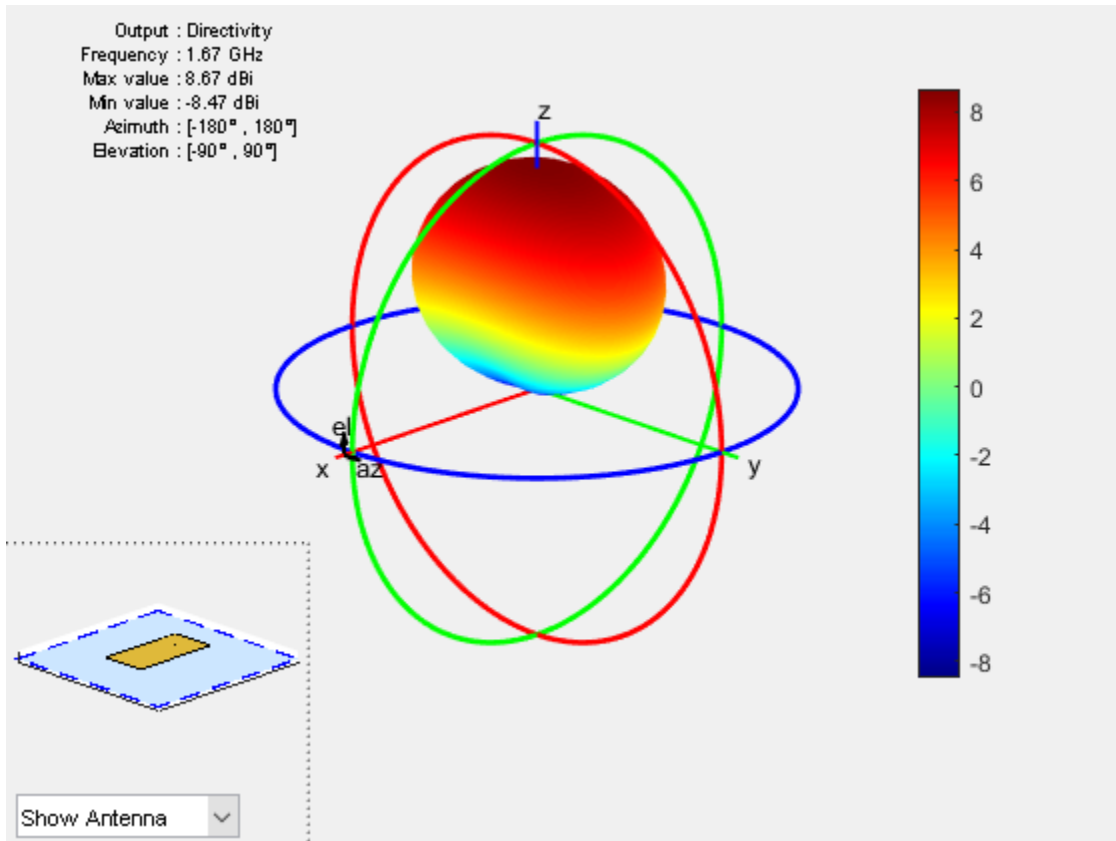

### Visualize Antenna Mesh

Mesh and view the infinite ground plane patch microstrip antenna.

```
figure;  
mesh(p);
```

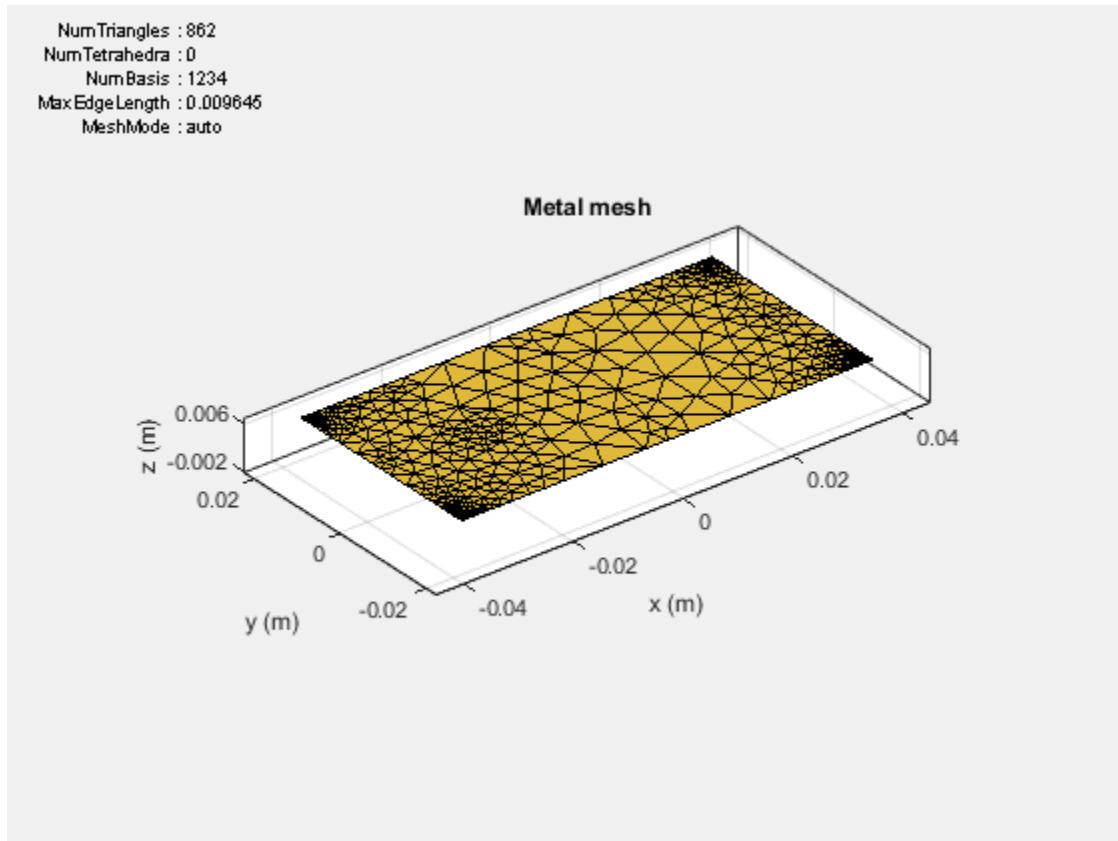

# Array Concepts

---

- “Mutual Coupling” on page 2-2
- “Beamforming” on page 2-15
- “Grating Lobes” on page 2-20
- “Correlation Coefficient” on page 2-23
- “Infinite Arrays” on page 2-25
- “Manipulate Array Elements” on page 2-41

## Mutual Coupling

| In this section...                                    |
|---|
| “Active or Scan Impedance” on page 2-2                |
| “Mutual Impedance” on page 2-3                        |
| “Coupling Matrix” on page 2-4                         |
| “Array Factor and Pattern Multiplication” on page 2-6 |
| “Isolated Element Pattern” on page 2-12               |
| “Embedded Element Pattern” on page 2-13               |

*Mutual coupling* is the electromagnetic interaction between the antenna elements in an array. The current developed in each antenna element of an array depends on their own excitation and also on the contributions from adjacent antenna elements. Mutual coupling is inversely proportional to the spacing between the different antenna elements in an array. Mutual coupling in an array causes:

- Changes in the radiation pattern of the array
- Changes in the input impedance of the individual antenna elements in an array

To characterize mutual coupling, you can use mutual impedance, S-parameters, a coupling matrix, or an embedded element pattern.

### Active or Scan Impedance

*Active impedance*, or *scan impedance*, is the input impedance of each antenna element in an array, when all elements are excited.



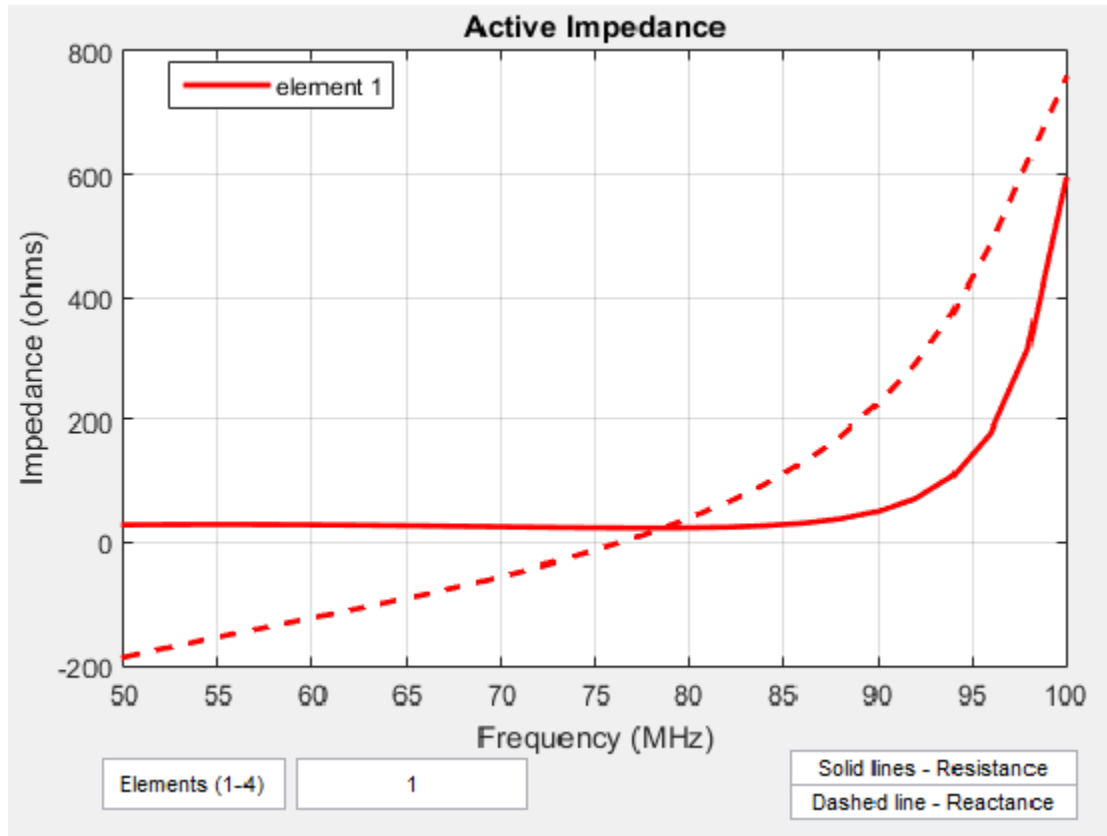

The active impedance of an array depends on:

- Array configuration
- Spacing between elements
- Phase shift applied at each element

## Mutual Impedance

The effect of mutual coupling is observed or modeled by varying the space between the antenna elements in the array. Any change in the inter-element spacings changes the *mutual impedance* between the antenna elements. For example, the plot shows the mutual impedance of a two-element dipole array as a function of inter-element spacing.

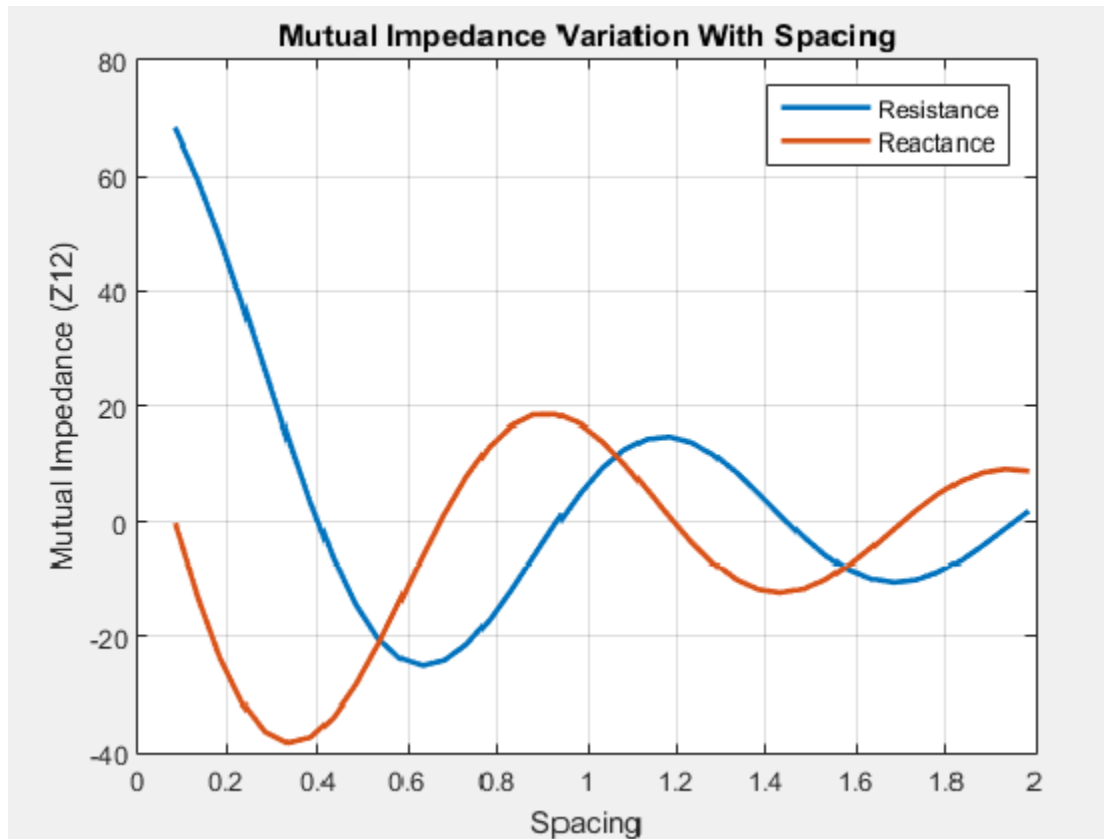

The plot shows that as the spacing between elements increases, the mutual impedance, and hence mutual coupling decreases.

### Coupling Matrix

A *coupling matrix* is used to characterize the mutual coupling between the antenna elements at the port level. This matrix is calculated using S-parameters or Z-parameters and is used to decouple the array.

### S-Parameter Matrix

To calculate the coupling matrix, you can use the S-parameter matrix. You calculate each column of the S-parameter matrix by feeding the antenna in that column by 1V. Consider

an element array arranged in a 2x2 grid. Visualize the grid and the element numbers using the layout.

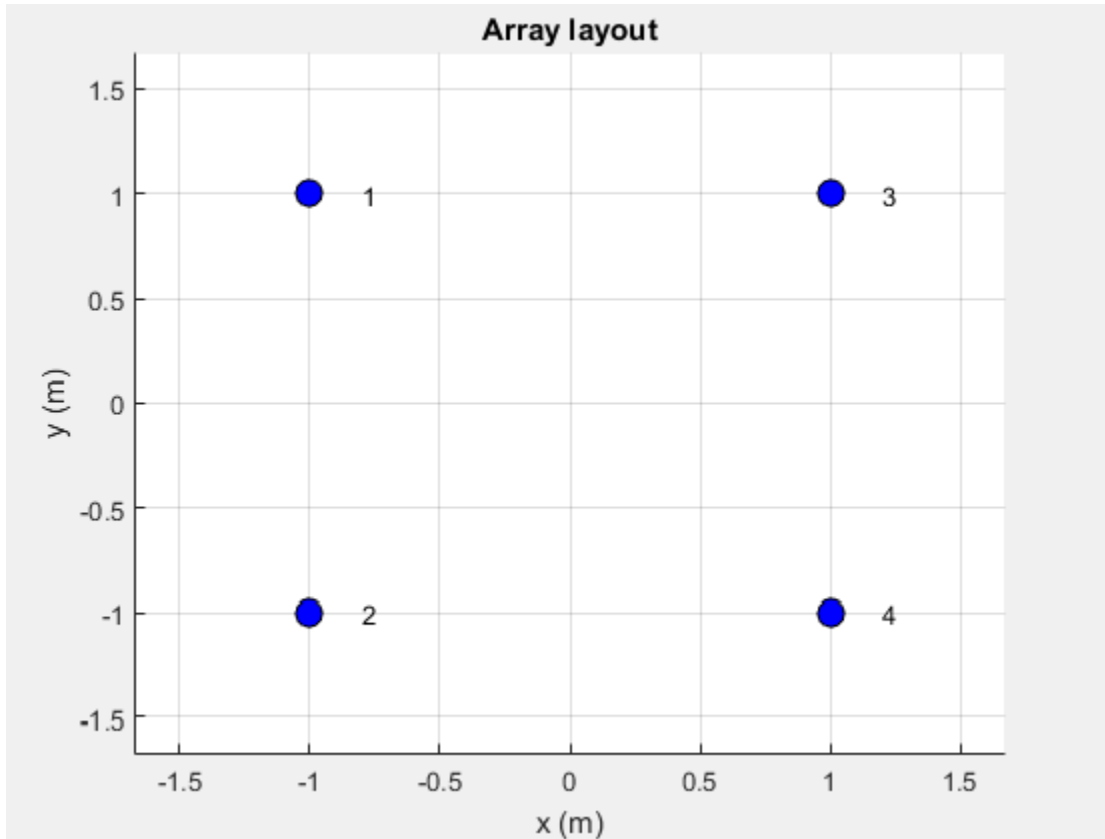

There are four ports in this array. The corresponding S-parameter matrix would be of size 4 x 4:

$$S = \begin{pmatrix} s_{11} & s_{12} & s_{13} & s_{14} \\ s_{21} & s_{22} & s_{23} & s_{24} \\ s_{31} & s_{32} & s_{33} & s_{34} \\ s_{41} & s_{42} & s_{43} & s_{44} \end{pmatrix}$$

During this measurement, terminate rest of the antenna elements using reference resistance of 50 ohms. The termination resistance is internally set to a default of 50 ohms and can be omitted during the calculation. If the termination is different, specify the resistance value when using this function. The diagonal terms in the matrix shown, represent the self-interaction which is also commonly referred to as the reflection coefficient. The off-diagonal terms capture the mutual coupling between the ports of the antenna.

Use `sparameters` to calculate the S-parameter coupling matrix of an array in Antenna Toolbox.

### Array Factor and Pattern Multiplication

The basis of the array theory is the *pattern multiplication* theorem. This theorem states that the combined pattern of N identical array elements is expressed as the element pattern times the array factor.

The array factor is calculated using the formula:

$$AF = \sum_{i=0}^N V(i) \cdot e^{(k \sin \theta \cos \phi \cdot x(i) + k \sin \phi \cdot y(i) + k \cos \theta \cdot z(i))}$$

where:

- $N$  is the number of elements in the array.
- $V$  is the applied voltage (amplitude and phase) at each element in the array.
- $k$  is the wave number.
- $\theta$  and  $\phi$  are the elevation and azimuth angles.
- $x$ ,  $y$ , and  $z$  are the Cartesian coordinates of the feed locations for every antenna element of the array.

Once the array factor is calculated using the above equation, you can calculate the beam pattern of the array as the product of the array factor and the beam pattern of the individual antenna element of the array.

*Array pattern = AF\* individual antenna element pattern*

The analysis assumes that the array elements are uncoupled. This means that the current in one element does not excite currents in the other elements or there is no mutual

coupling between different elements of the array. This is the most serious limitation of the pattern multiplication theorem, restricting its use to arrays with large element spacing.

For example:

Calculate the array pattern of the rectangular array of dipoles in the x-y plane with a spacing of half-lambda

```
fc = 1e9;
lambda = physconst('lightspeed')/fc;
az = -180:0.1:180;
el = -90:0.1:90;

%% Element
d = design(dipole,1e9);
d.Tilt = 90;
d.TiltAxis = [0 1 0];

%% Array
r = rectangularArray;
r.Element = d;
r.RowSpacing = lambda/2;
r.ColumnSpacing = lambda/2;
figure; show(r) ;
figure; patternMultiply(r, fc, az, el);
```

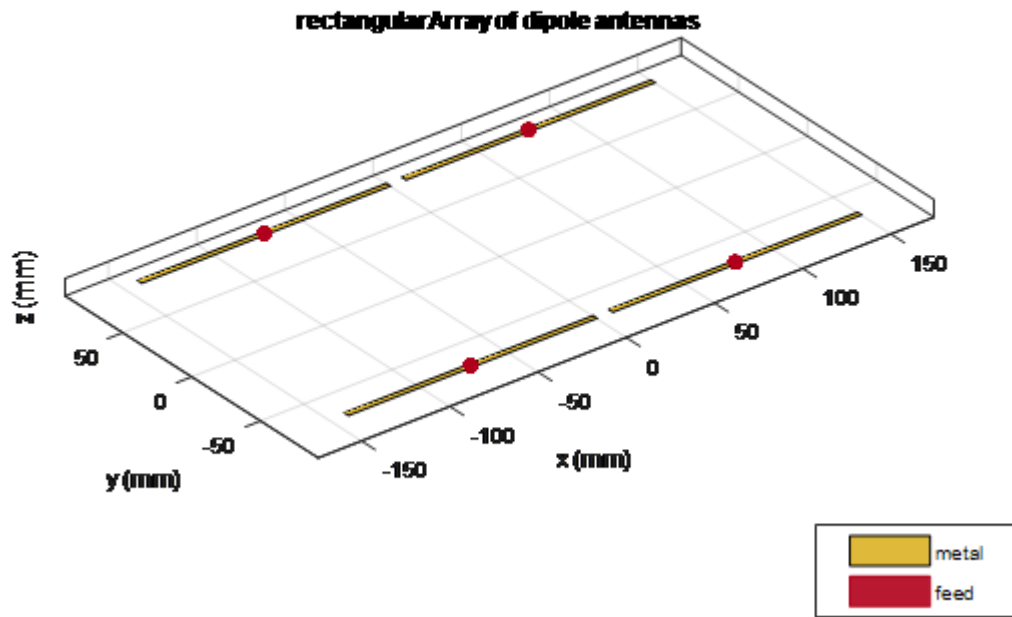

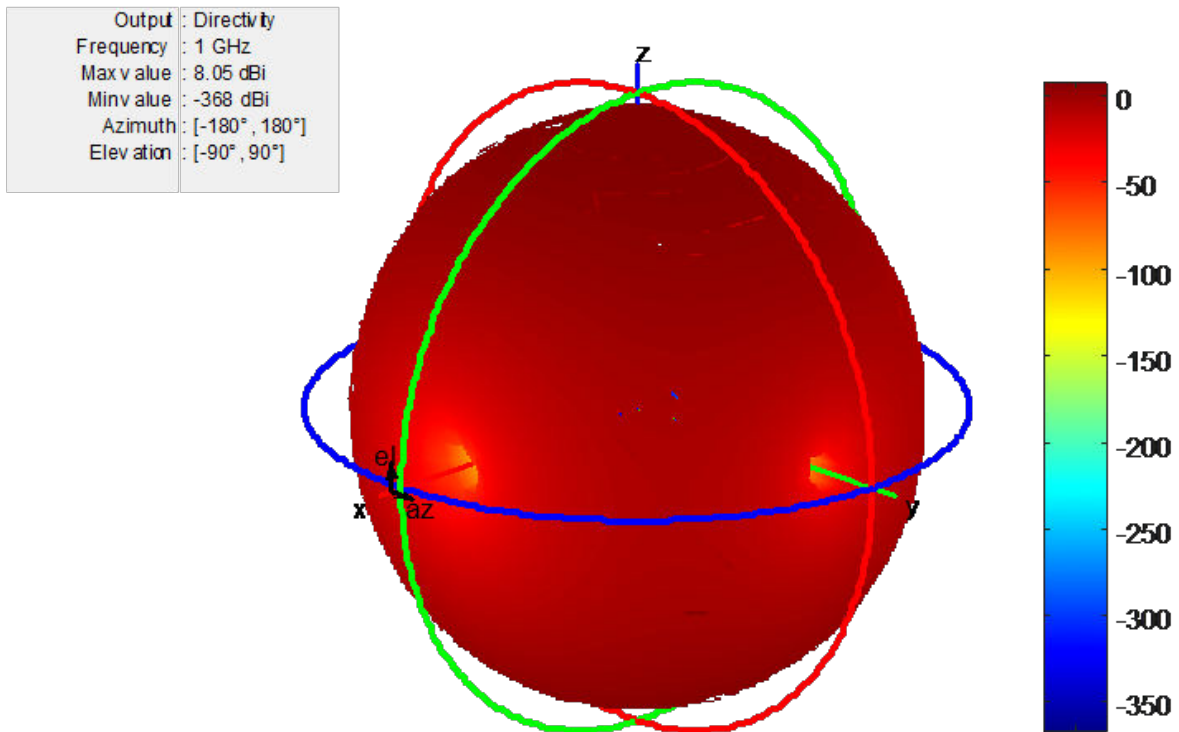

Increase the size of the rectangular array to 200k elements. Below is the time taken for the computation and the calculated directivity.

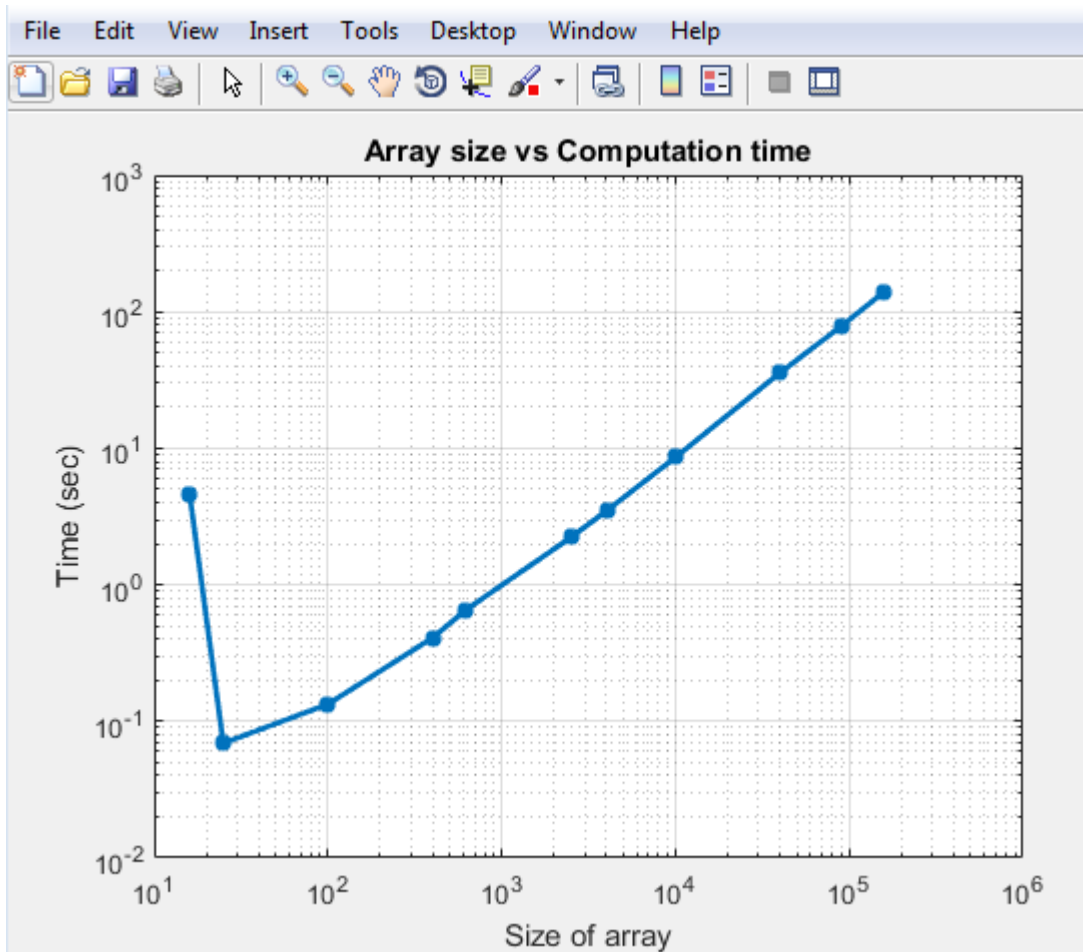



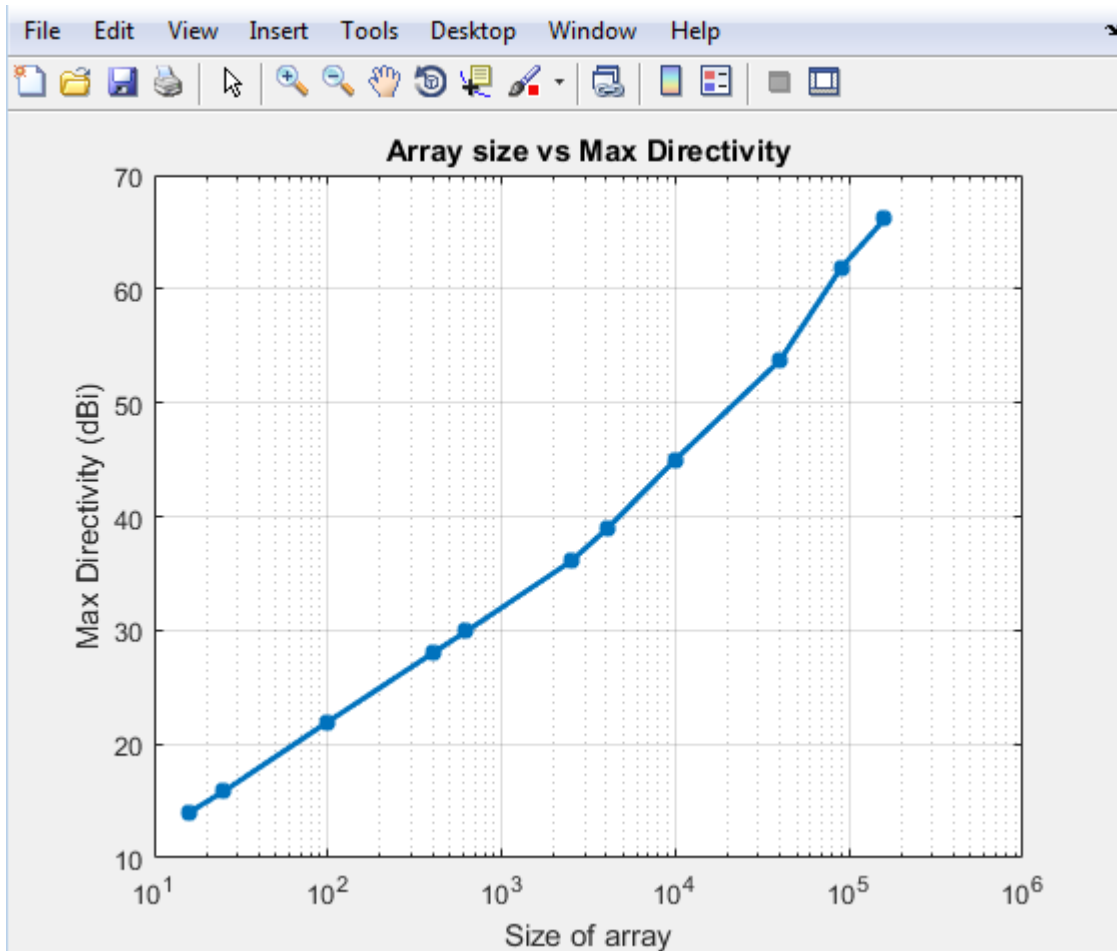

You see that the time taken to solve a 100k array is less than 100 seconds. The initial bump in time for the small array is because you perform EM analysis to compute the pattern of the individual dipole element in the array. Once this analysis is done the results are cached and the successive calls do not perform any EM analysis. As a result the increase in time is fairly linear. This is the biggest advantage of using pattern multiplication. It lets you solve large arrays quickly and with limited memory requirements.

## Isolated Element Pattern

Patterns of individual elements in small arrays vary significantly. Therefore you cannot use pattern multiplication for complete array pattern because isolated element pattern assumes that all elements have the same pattern.

You can calculate the complete array pattern of small arrays by plotting the pattern all the elements separately in a small array. To obtain this pattern, each element is individually excited and the rest of the array elements terminated using reference impedance. The plot shows the radiation pattern of individual elements of 4--element array.

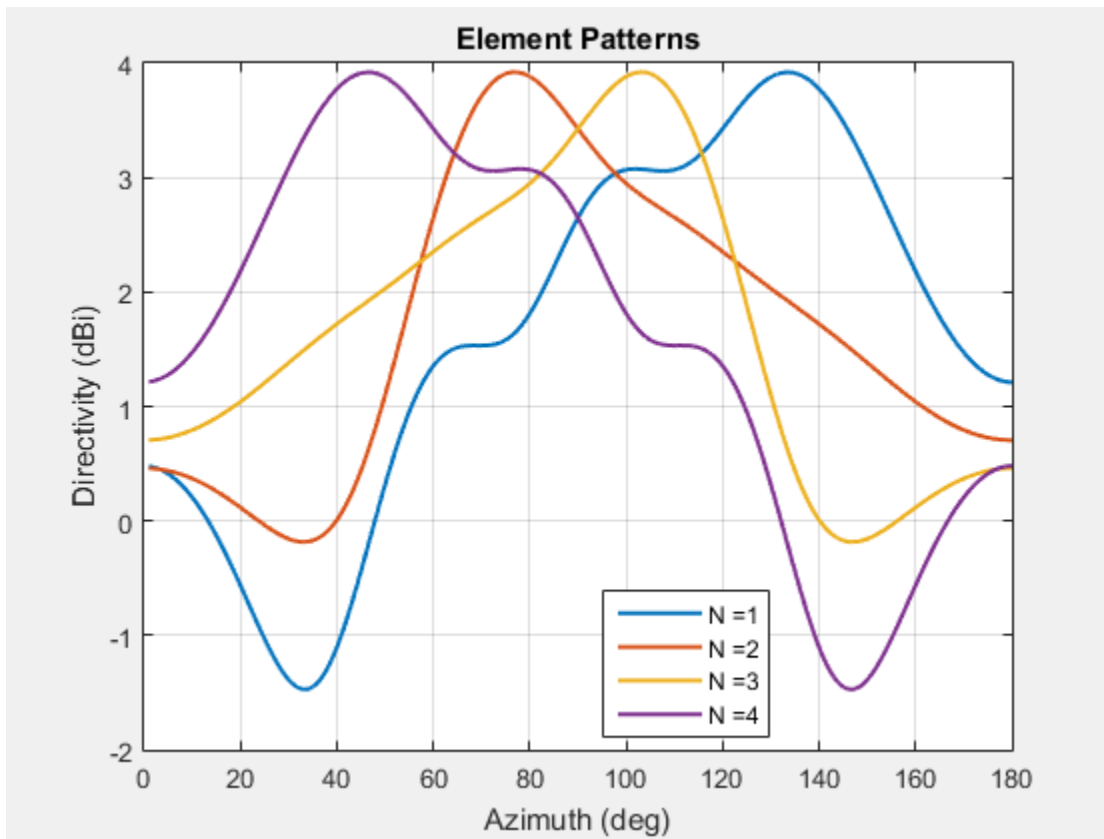

## Embedded Element Pattern

The *embedded element pattern* is the pattern of a single element embedded in a finite array, calculated by driving a specific (typically the central) element in the array. The rest of the array elements are terminated using reference impedance. This method is useful for large array because the effect of mutual coupling on the individual element is captured. It is important to note that the edge effects can be ignored since the size of the array is assumed to be very large. It is common to use the center antenna element for this calculation. Due, to the size of the array the radiation patterns of the elements in the array can be approximated with the embedded element pattern instead of the isolated element pattern. Finally, pattern multiplication is used to calculate the complete array pattern.

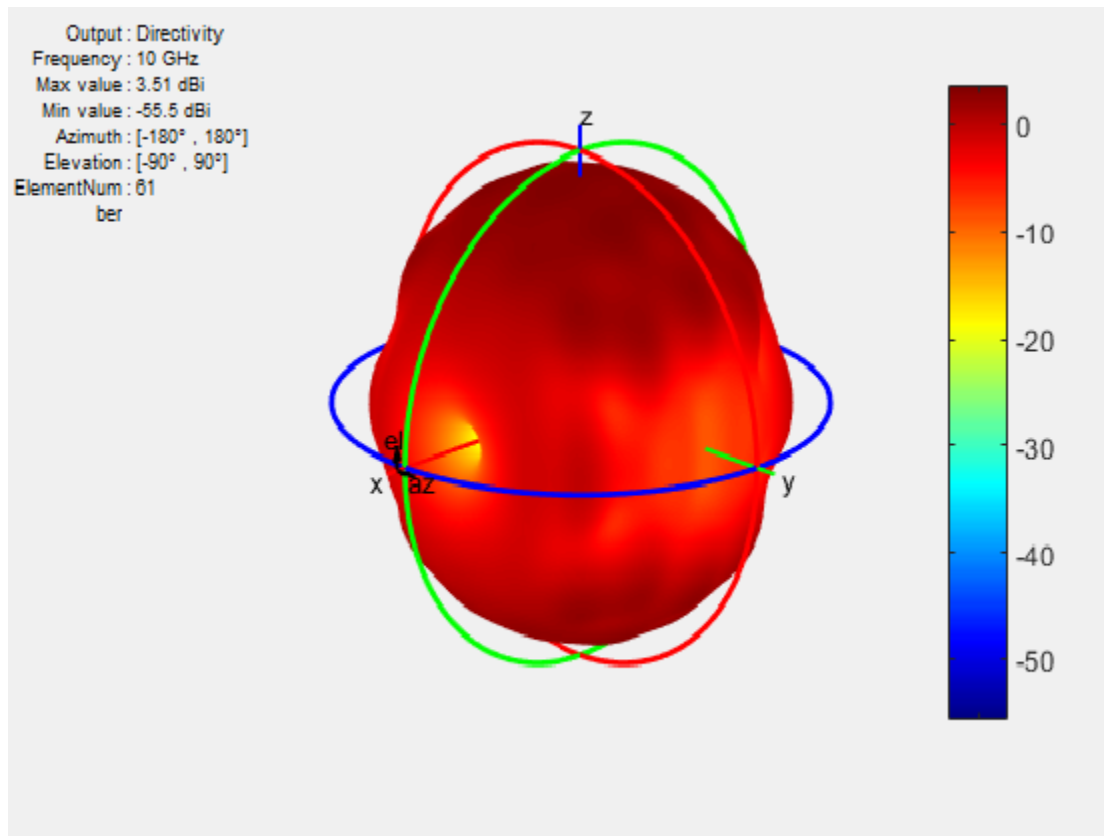

The figure shows the embedded element pattern of a center element in a 11x11 array. You can also calculate the embedded element pattern as a magnitude of electric field.

Isolated element pattern is not recommended for large arrays as this method does not account for the coupling effects of elements around it.

### **Scan Blindness**

In large arrays, it is possible that the array directivity reduces drastically at certain scan angles. At these scan angles, referred to as the blind angles, the array does not radiate the power supplied at its input terminals [3]. The scan blindness can occur while using these common mechanisms:

- Surface wave excitation
- Grating lobe excitation

To detect scan blindness in large finite arrays, study the embedded element pattern. In infinite array analysis, this pattern is known as the array element pattern.

### **References**

- [1] Stutzman, W.L. Thiele, G.A. *Antenna Theory and Design*, 3rd Edition. New York: Wiley, 2013, p. 307.

# Beamforming

| In this section...               |
|----------------------------------|
| “Side Lobe Control” on page 2-15 |
| “Beam Scanning” on page 2-17     |

*Beamforming* is the process of generating a directional beam from an antenna array. Achieve beamforming by weighting individual elements by using side lobe control or beam scanning.

## Side Lobe Control

Side lobes are undesired and lead to reception or transmission of energy in unwanted directions. *Side lobe control* in an array is achieved using amplitude taper or amplitude weighting. Amplitude tapering changes the excitation amplitude of each element in the array. Minor lobe levels are controlled using amplitude taper that runs from the center of the array to the end of the array. Smoother amplitude tapering gives larger small side lobe levels but half-power beamwidth. These arrays are non-uniformly excited arrays.

Consider a linear array of 21 elements. Without amplitude tapering, the array contains unwanted side lobes in the desired direction:

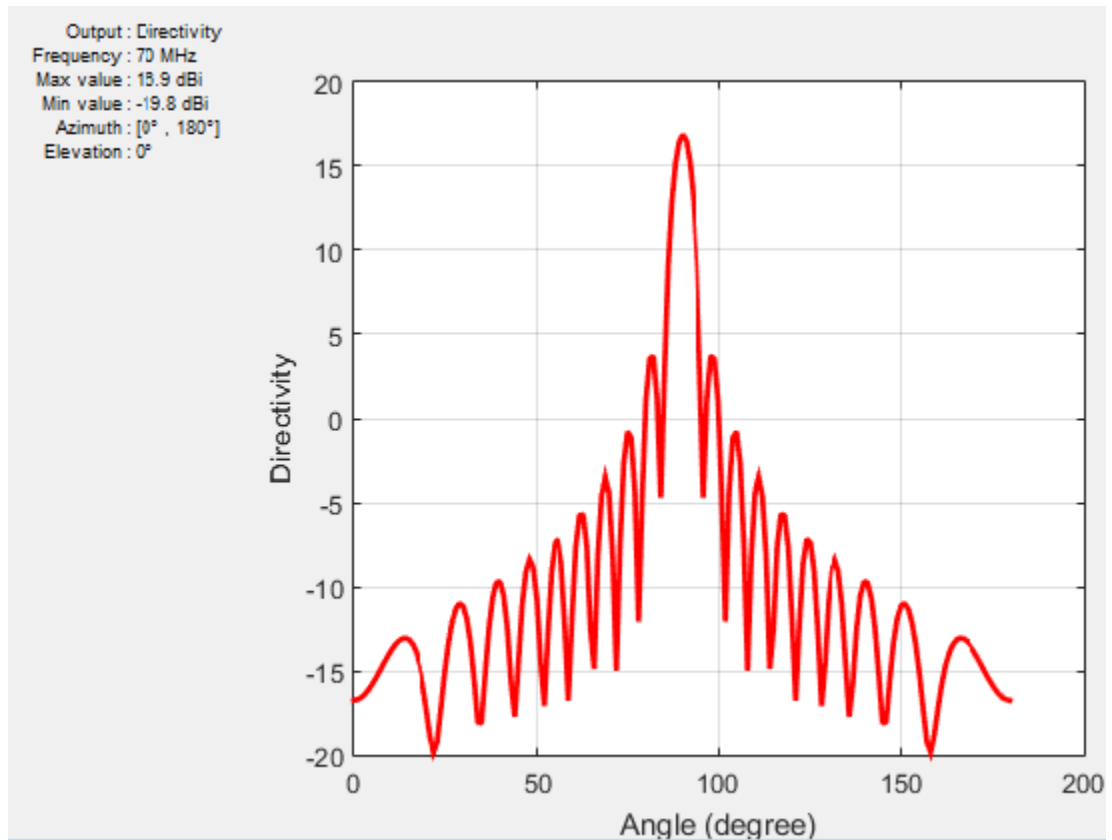

By using amplitude tapering on the linear array, you control the side lobes and achieve a better main beam in the desired direction:

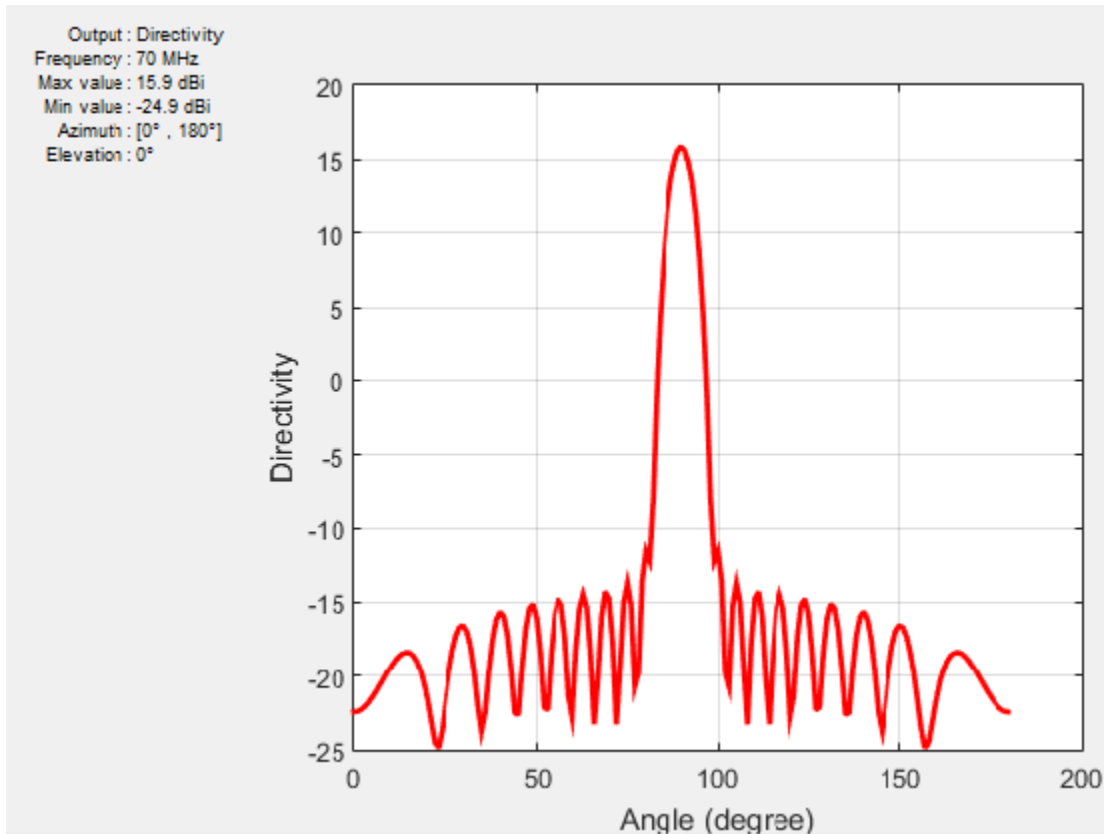

## Beam Scanning

*Beam scanning* is the movement of a radiation pattern in space. You can achieve beam scanning by controlling the progressive phase difference between the elements to direct the beam in any desired direction. The phase shift changes the phase of the excitation currents of each element in an array. You can achieve this phase shift using phase shifter devices, a time delay, frequency scanning, beam switching, or digital beamforming.

Consider a linear array of 21 elements where peak directivity is shown without beam scanning:

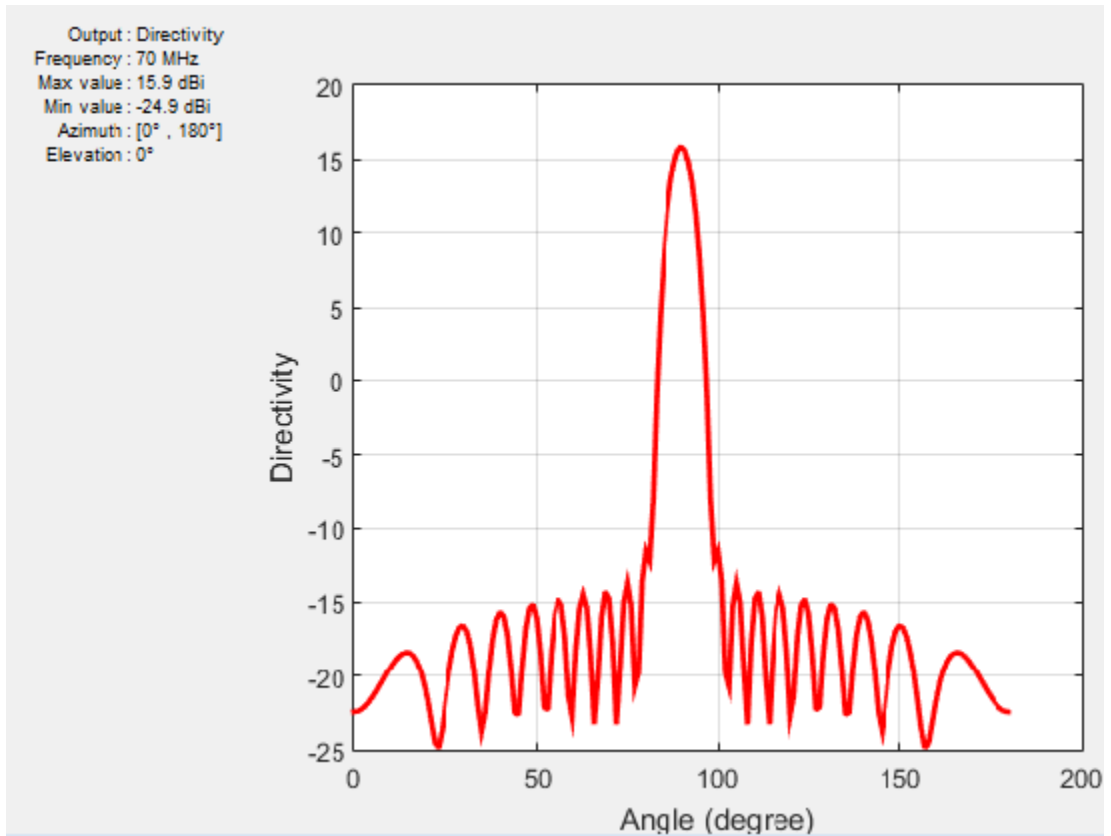

To scan the beam at a specific angle, use phase shift on the linear array:



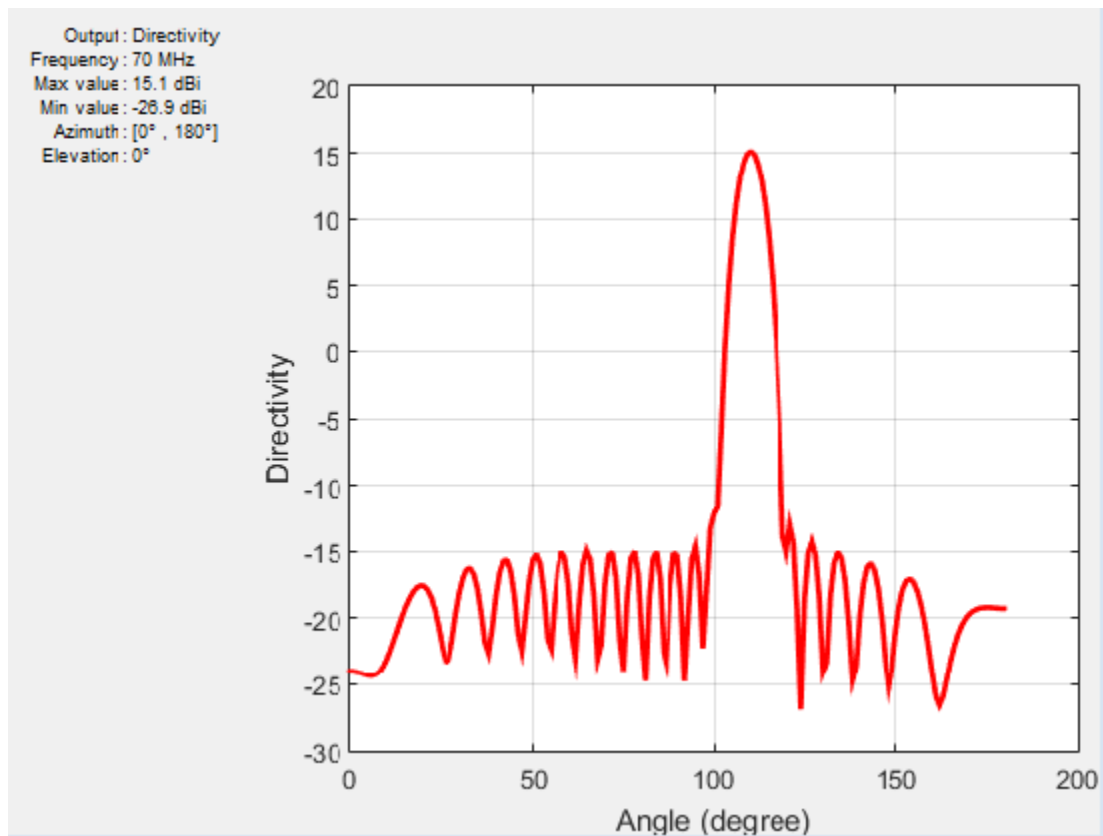

## References

- [1] Stutzman, W.L. Thiele, G.A. *Antenna Theory and Design*, 3rd Edition. New York: Wiley, 2013, p. 307.

## Grating Lobes

*Grating lobes* are the maxima of the main beam, as predicted by the pattern multiplication theorem. When the array spacing is less than or equal to  $\lambda/2$ , only the main lobe exists in the visible space, with no other grating lobes. Grating lobes appear when the array spacing is greater than  $\lambda/2$ . For large spacing, grating lobes can appear in the visible space even at a zero scan angle.

Consider a linear array of seven elements spaced one-half wavelength apart. This array contains no grating lobes.

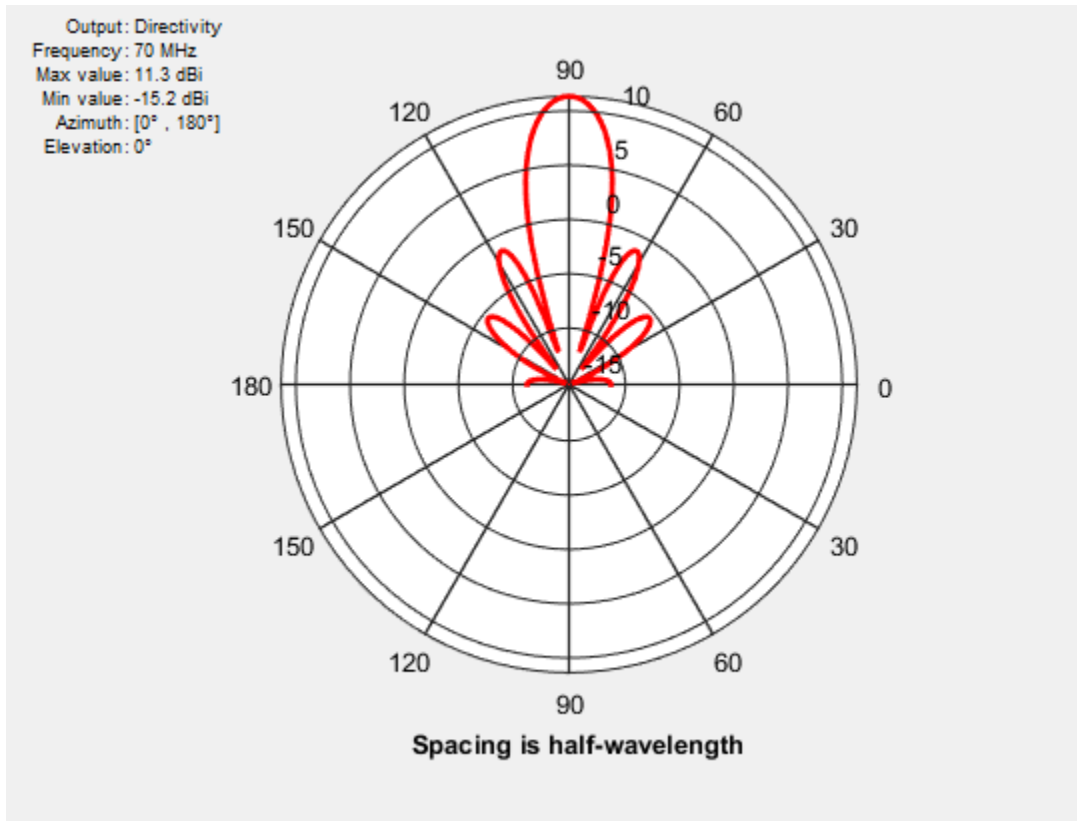

When you increase the element spacing to one wavelength, the number of side lobes increases.

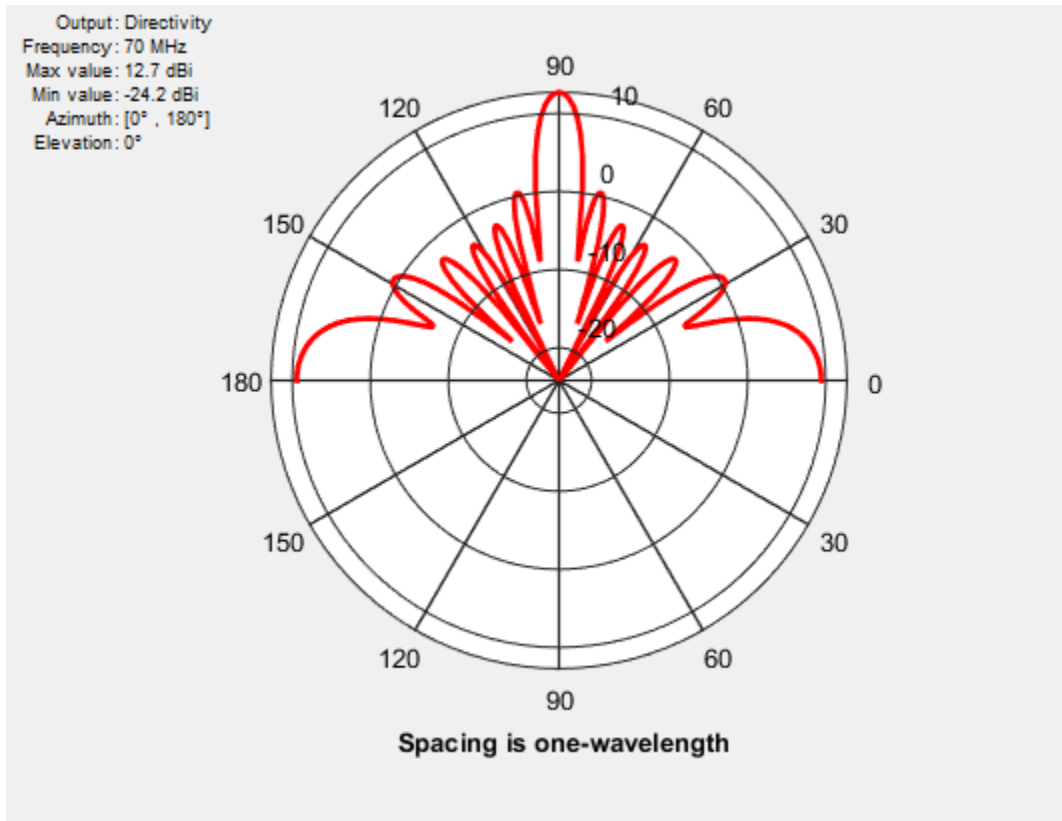

When you increase the element spacing to 1.5 wavelengths apart, the grating lobes appear in the visible region.

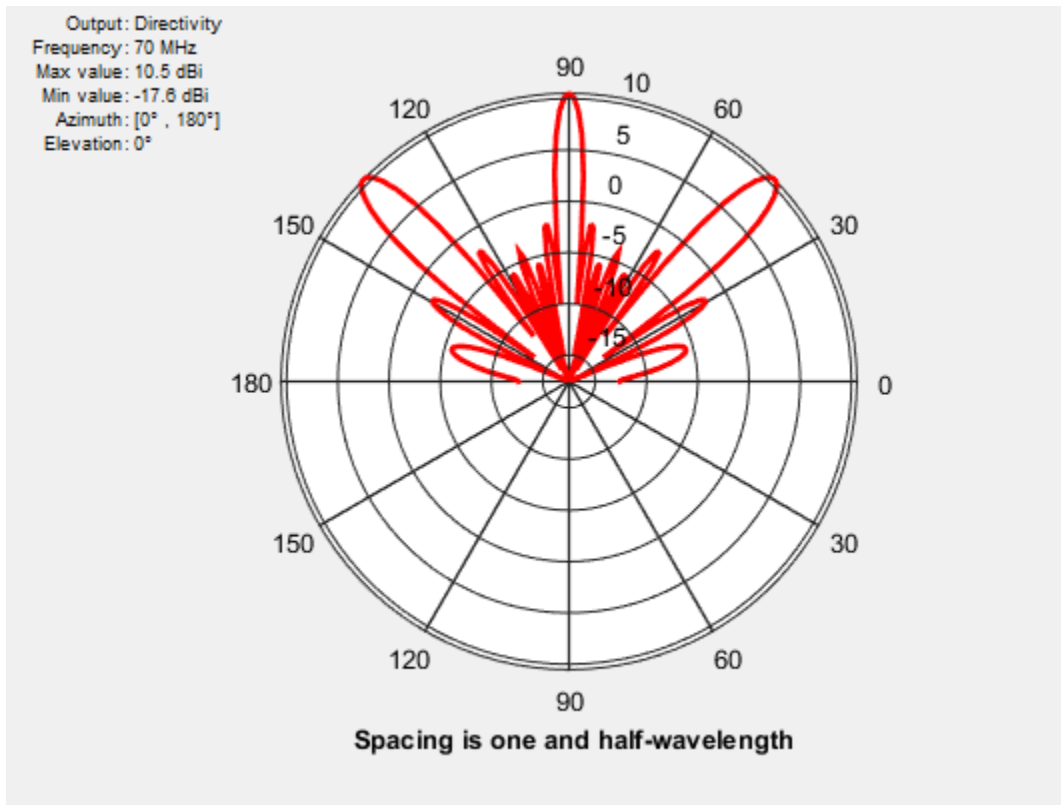

The grating lobes move in or out of the visible region depending on the spacing between the elements and the relative phase between them.

### References

- [1] Stutzman, W.L. Thiele, G.A. *Antenna Theory and Design*, 3rd Edition. New York: Wiley, 2013, p. 307.

## Correlation Coefficient

### In this section...

“Far-Field Radiation Pattern” on page 2-23

“S-Parameter Characterization” on page 2-23

The *correlation coefficient* is the relationship between the incoming signals at the antenna ports in an array. Mutual coupling in array systems degrades the performance of the array. The correlation coefficient between antennas is used as a performance metric in multiple-input multiple-output (MIMO) systems to quantify the system performance and efficiency of the antennas. By using the correlation coefficient, a MIMO system designer is able to understand the level of coupling that exists between the antenna ports in the system. To minimize the mutual coupling would imply to reduce the correlation coefficient between the pairs of ports. Antenna designers use two approaches to calculate correlation coefficient: the far-field Radiation pattern and S-parameters.

### Far-Field Radiation Pattern

The correlation coefficient of a two antenna array system is:

$$\rho_e = \frac{\left| \int_{4\pi} \int [\vec{F}_1(\theta, \phi) \cdot \vec{F}_2(\theta, \phi)] d\Omega \right|^2}{\int_{4\pi} \int |\vec{F}_1(\theta, \phi)|^2 d\Omega \int_{4\pi} \int |\vec{F}_2(\theta, \phi)|^2 d\Omega}$$

where  $\vec{F}_i(\theta, \phi)$  is the radiation pattern of the antenna system when port  $i$  is excited. Computing the correlation coefficient using this formula, requires the radiation pattern of the antenna. This approach is hard and time consuming.

### S-Parameter Characterization

Antenna Toolbox™ uses the S-parameter characterization to calculate correlation between antenna elements in an array. This approach is simpler than the far-field approach because the S-parameter calculation does not use the radiation patterns of the antennas. Correlation coefficient is calculated using S-parameter by using:

$$\rho_e = \frac{|S_{11}^* S_{12} + S_{21}^* S_{22}|^2}{(1 - (|S_{11}|^2 + |S_{21}|^2))(1 - (|S_{22}|^2 + |S_{12}|^2))}$$

The advantages of this method are quick analysis and broadband correlation results. However, this approach assumes that the antennas are lossless and that incoming waves are uniformly distributed. To calculate and plot the correlation between antennas in an array, use the `correlation` function in Antenna Toolbox™.

### References

- [1] Blanch, S. Romeu, J. and Corbella, I. *Exact Representation of antenna system diversity performance from input parameter description*
- [2] Stutzman, W.L. Thiele, G.A. *Antenna Theory and Design*, 3rd Edition. New York: Wiley, 2013, p. 307.

# Infinite Arrays

**In this section...**

“What Are Infinite Arrays?” on page 2-25

“Infinite Array Analysis” on page 2-25

“Create Infinite Array Using Antenna Toolbox” on page 2-26

“Choose a Unit Cell” on page 2-27

“Scan Infinite Arrays” on page 2-30

“Scan Impedance and Scan Element Pattern” on page 2-30

“Compare Scan Element Pattern of Finite and Infinite Arrays” on page 2-31

“Impact of Infinite Double Summation” on page 2-37

## What Are Infinite Arrays?

Infinite arrays are rectangular arrays of infinite extent. In an infinite array, a single element called a *unit cell*, is repeated uniformly an infinite number of times along a plane.

## Infinite Array Analysis

All arrays used in real-world scenarios are finite. But antenna arrays used in radio astronomy, air defense, or surveillance radar can have more than 1000 antenna elements. In such large arrays, the electromagnetic analysis of each element is tedious and time consuming.

Infinite array analysis ignores the effect of truncation (edge effect) at array edges. The method analyzes the behavior of the active antenna element as a function of frequency and scan. The goal of infinite array analysis is to extract the behavior of the active antenna element embedded in the array.

### Assumptions

For infinite array analysis, array size must be greater than  $10 \times 10$ . The technique makes other assumptions:

- Each element is identical.
- Each element is uniformly excited in amplitude.

- All elements are spaced uniformly in two dimensions.

### Infinite Array Solver

To model an infinite array, the method of moments (MoM) formulation is changed to account for the infinite behavior by replacing Green's functions with periodic Green's functions. The periodic Green's function is an infinite double summation.

| Green's Function                                    | Periodic Green's Function  |
|---|--|
| $g = \frac{e^{-jkR}}{R}$ $R =  \vec{r} - \vec{r}' $ | $g_{\text{periodic}} = \sum_{m=-\infty}^{\infty} \sum_{n=-\infty}^{\infty} e^{j\phi_{mn}} \frac{e^{-jkR_{mn}}}{R_{mn}}$ $R_{mn} = \sqrt{(x - x' - x_m)^2 + (y - y' - y_n)^2 + (z - z')^2}$ $\phi_{mn} = k(x_m \sin\theta \cos\varphi + y_n \sin\theta \cos\varphi)$ $x_m = m \cdot d_x, y_n = n \cdot d_y$ |

$d_x$  and  $d_y$  are the ground plane dimensions that define the  $x$  and  $y$  dimensions of the unit cell.  $\theta$  and  $\Phi$  are the scan angles.

The periodic Green's function has an additional exponential term added to the infinite sum. The  $\phi_{mn}$  term accounts for the scanning of the infinite array. The periodic Green's function also accounts for the effect of mutual coupling.

### Create Infinite Array Using Antenna Toolbox

To create an infinite array, use the `infiniteArray` object to repeat a single antenna element (unit cell), infinitely along the X-Y plane. The `layout` function displays a typical unit cell.

```
infarray = infiniteArray;
layout(infarray)
```



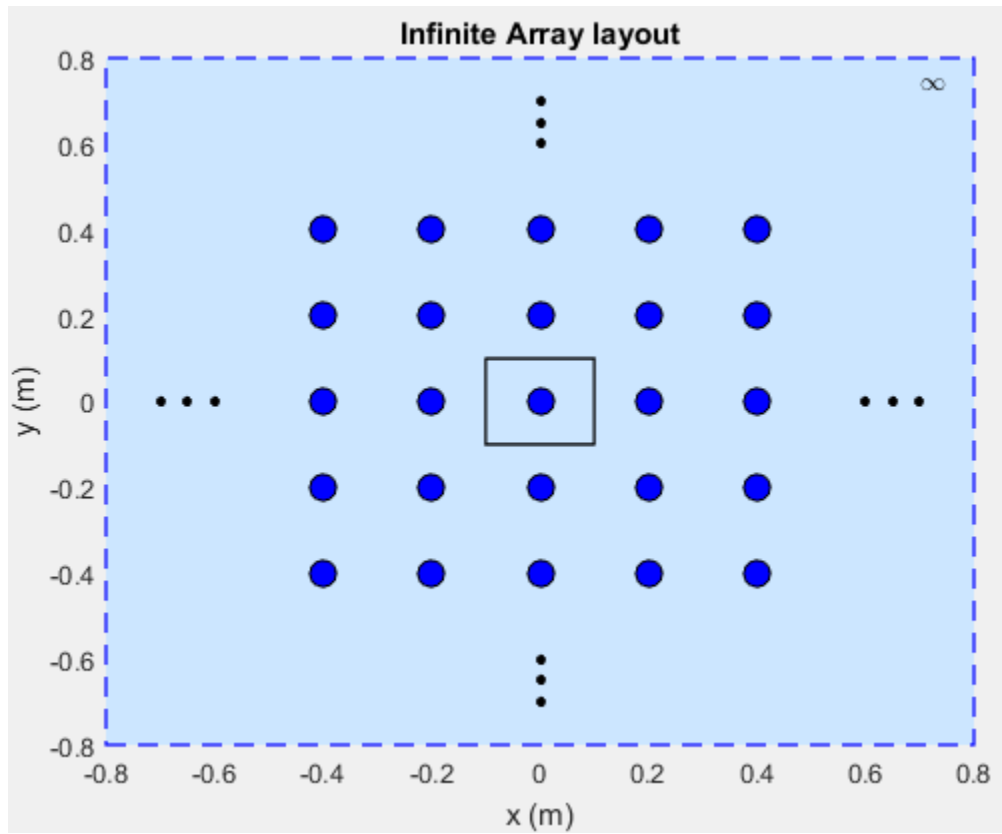

## Choose a Unit Cell

You can use any antenna from the Antenna Toolbox as the unit cell. The unit cell requires a ground plane to specify the boundaries. You can use a reflector to back antennas that do not have a ground plane.

The default reflector properties are:

`r = reflector`

reflector with properties:

```
Exciter: [1x1 dipole]
GroundPlaneLength: 0.2000
```

```
GroundPlaneWidth: 0.2000
Spacing: 0.0750
Tilt: 0
TiltAxis: [1 0 0]
```

The default unit cell in an infinite array is a reflector that has a dipole as an exciter. The `Spacing` property gives the distance between the reflector and the exciter. The default infinite array properties are:

```
infarray = infiniteArray
```

```
infiniteArray with properties:
```

```
Element: [1x1 reflector]
ScanAzimuth: 0
ScanElevation: 90
```

```
show (infarray)
```

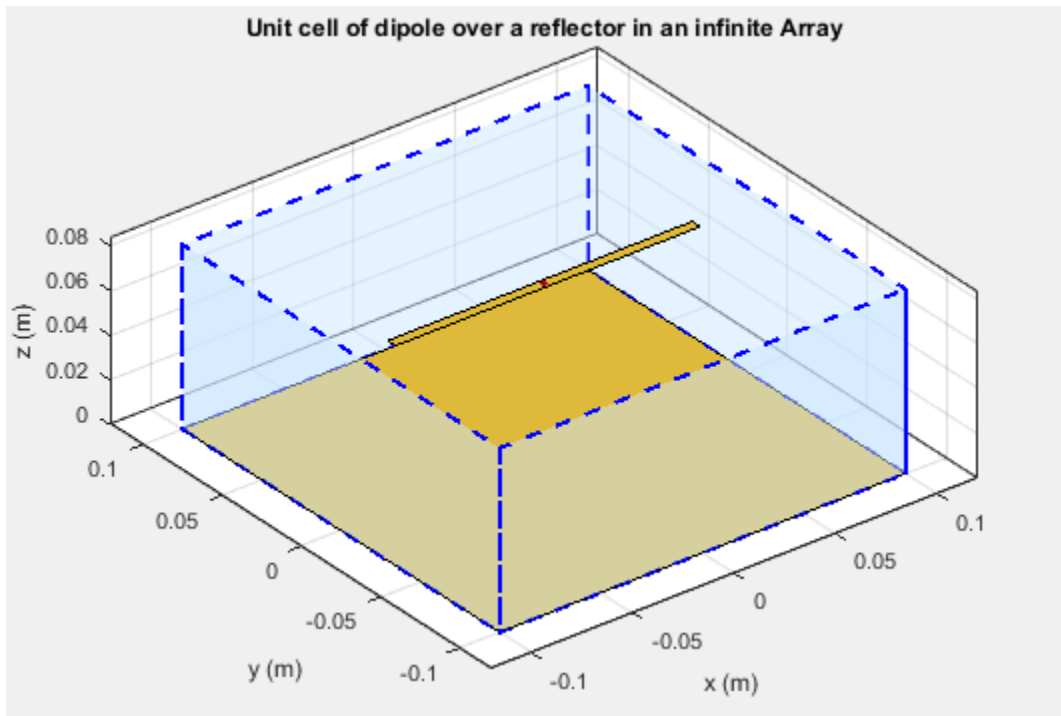

The dotted blue box bounds the unit cell. Ground plane length and ground plane width of the unit cell are the dimensions of the antenna element of the infinite array.

An antenna with a ground plane, such as a microstrip patch antenna, is specified directly as an `Element` of an infinite array.

```
infarray = infiniteArray('Element', patchMicrostrip)
```

```
infarray =  
  infiniteArray with properties:  
  
    Element: [1x1 patchMicrostrip]  
   ScanAzimuth: 0  
   ScanElevation: 90
```

```
show(infarray)
```

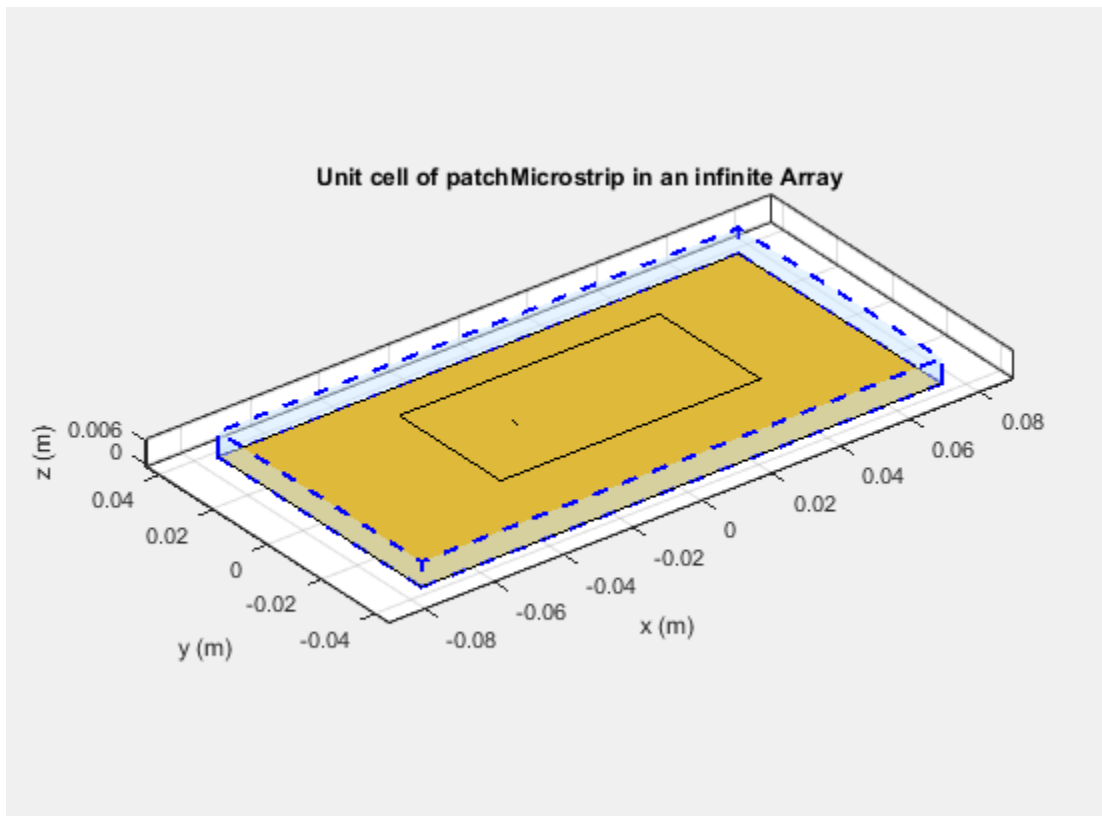

The Antenna Toolbox infinite array is located in the X-Y plane. Unit cells consisting of antennas with ground planes are also located in the X-Y plane. For antennas used as unit cells, such as the one in this example, you ignore the value of the `Tilt` property.

### Scan Infinite Arrays

You scan a finite array by specifying the appropriate phase shift for each antenna element. In Antenna Toolbox, you specify the scan angle (in azimuth and elevation) and frequency for infinite array analysis. By default, an array always scans at boresight (azimuth = 0 degrees and elevation = 90 degrees).

```
infarray = infiniteArray

infiniteArray with properties:

    Element: [1x1 reflector]
    ScanAzimuth: 0
    ScanElevation: 90
```

To change the scan angles, change the values of `ScanAzimuth` and `ScanElevation`.

### Scan Impedance and Scan Element Pattern

To calculate the scan impedance for an infinite array, use the `impedance` function as a function of scan angle. Fixing the scan angle pair and sweeping the frequency variable reveals the frequency dependency in the scan impedance. Because `ScanAzimuth` and `ScanElevation` are scalar values, you must a `for`-loop to calculate the complete scan impedance of the array. For more information on calculating the scan impedance and the scan element pattern see, "Infinite Array Analysis".

#### Scan Element Pattern

To calculate the scan element pattern using scan impedance, use these expressions:

$$g_s(\theta) = \frac{4R_g R_{\text{iso}} g_{\text{iso}}(\theta)}{|Z_s(\theta) + Z_g|^2}$$

- $R_g$  — Resistance of generator
- $Z_g$  — Impedance of generator
- $Z_s$  — Scan impedance

- $g_{\text{iso}}(\theta)$  — Pattern of isolated element
- $R_{\text{iso}}$  — Resistance of isolated element

The scan element pattern can also be expressed in terms of the reflection coefficient,  $\Gamma(\theta)$ :

$$g_s(\theta) = \frac{4R_{\text{iso}}g_{\text{iso}}(\theta)}{R_s(\theta)} (1 - |\Gamma(\theta)|^2)$$

The Antenna Toolbox software calculates the scan element pattern of a finite array by driving just a single element. You terminate all the other elements using a suitable impedance. The resulting element pattern includes mutual coupling and is valid for all scan angles.

## Compare Scan Element Pattern of Finite and Infinite Arrays

### Case 1: Compare finite array and infinite array with unit cell of dimensions $0.5\lambda \times 0.5\lambda$

To calculate the scan element pattern of the finite arrays, first, create a reflector-backed dipole. Set the dipole dimensions to Length( $L$ ) =  $0.495\lambda$  and Width( $W$ ) =  $\lambda/160$  and the ground plane dimensions to  $0.5\lambda \times 0.5\lambda$ . Place the dipole at a distance of  $h = \lambda/4$  from the reflector. The ground plane dimensions set the boundaries of the unit cell. Create finite arrays of sizes 11x11, 15x15, and 17x17 using this unit cell.

For finite arrays, calculate the scan element pattern by driving a single element in the array. Terminate all other finite array elements using the broadside resistance of the infinite array. For an infinite array with the unit cell of dimensions  $0.5\lambda \times 0.5\lambda$ , the broadside resistance is 176  $\Omega$ . Calculate the scan element pattern for E-, D-, and H-planes of all three finite arrays.

To calculate the scan element pattern of an infinite array, create an infinite array using the same unit cell and the `infiniteArray` class. Calculate the scan impedance for three scan planes: E, D, and H. Compute the pattern of the isolated element (dipole backed by reflector). Finally, use the equations from the previous section to generate the scan element pattern for the infinite array.

Perform all analysis at 10 GHz. To compare the patterns of finite and infinite array, overlay them on the same plot.

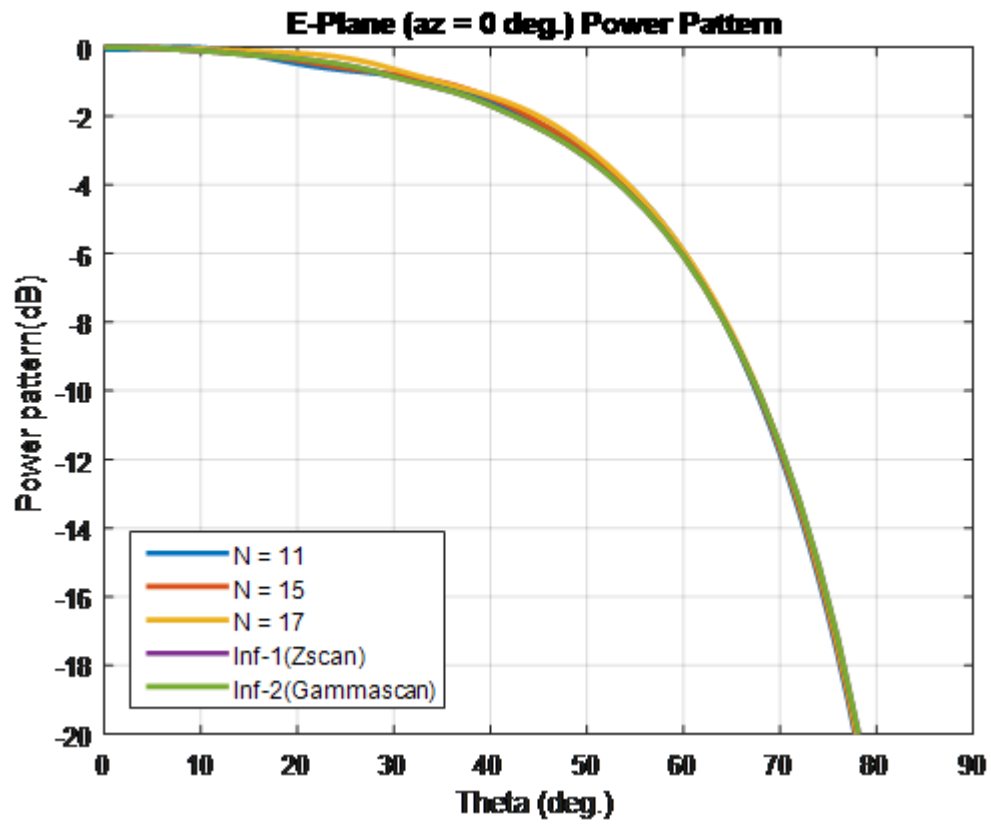

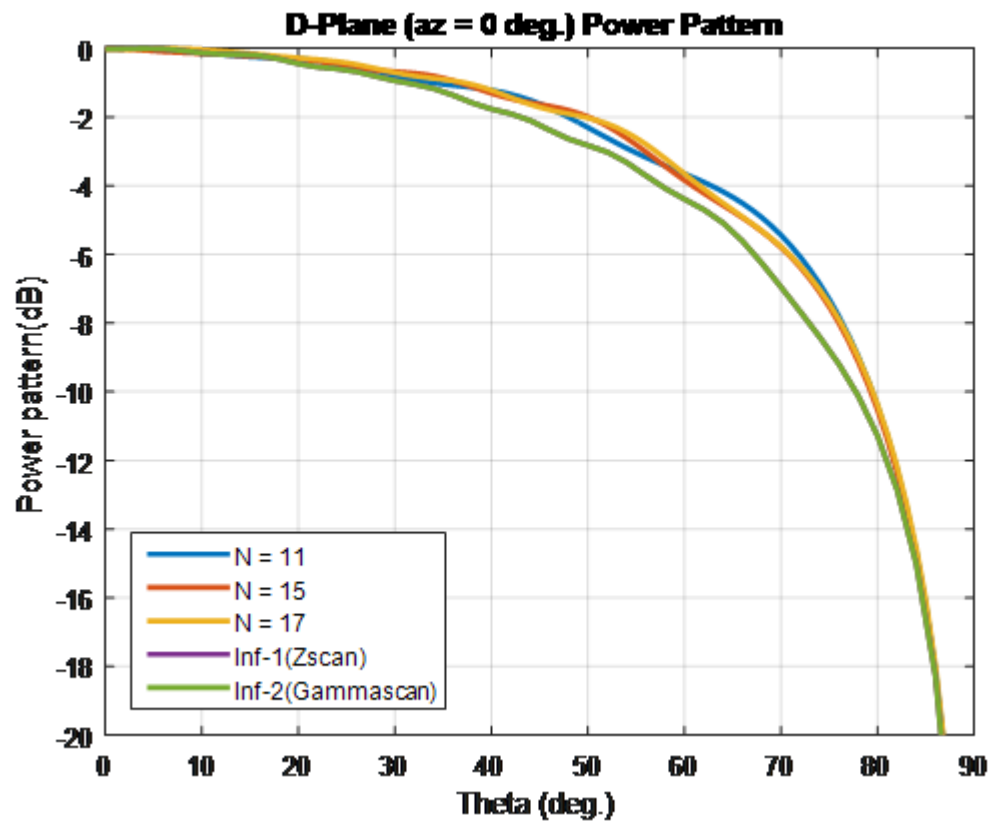

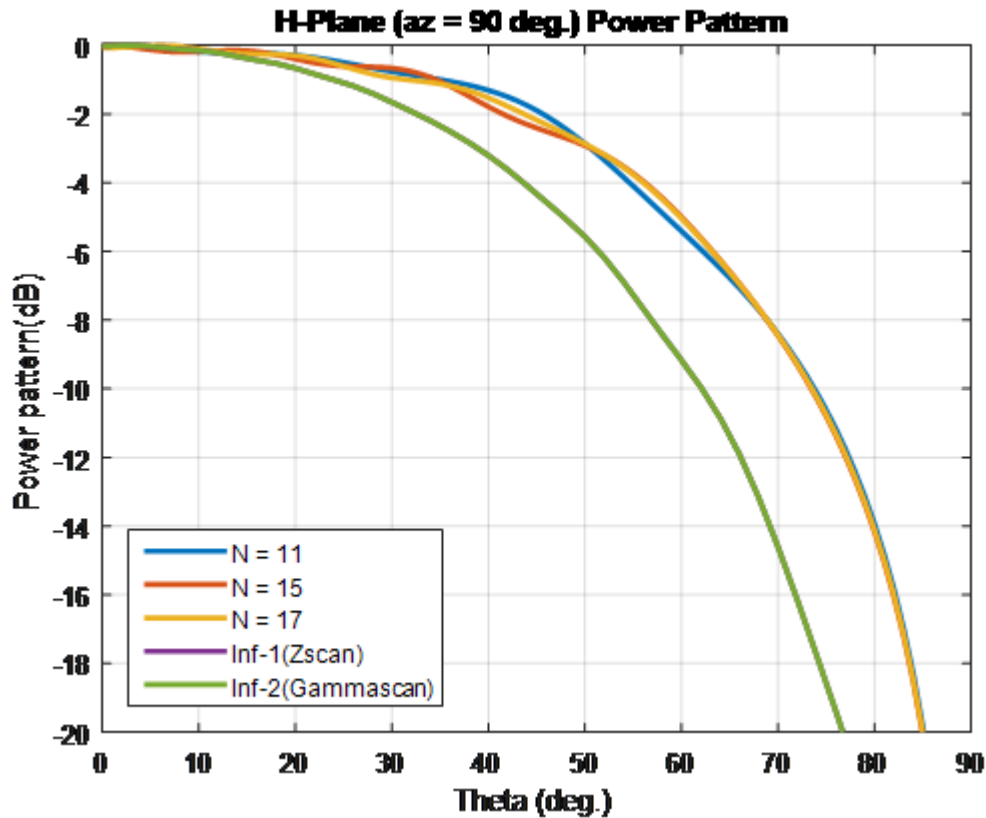

**Case 2: Compare finite array and infinite array with unit cell of dimensions  $0.7\lambda \times 0.7\lambda$**

To compare the scan element pattern of these array types and infinite arrays, repeat the process in case 1. Using these unit cell dimensions creates grating lobes. Terminate the finite arrays using  $86\text{-}\Omega$  resistance. For an infinite array with unit cell of dimensions  $0.7\lambda \times 0.7\lambda$ , the broadside resistance is  $86\ \Omega$ .



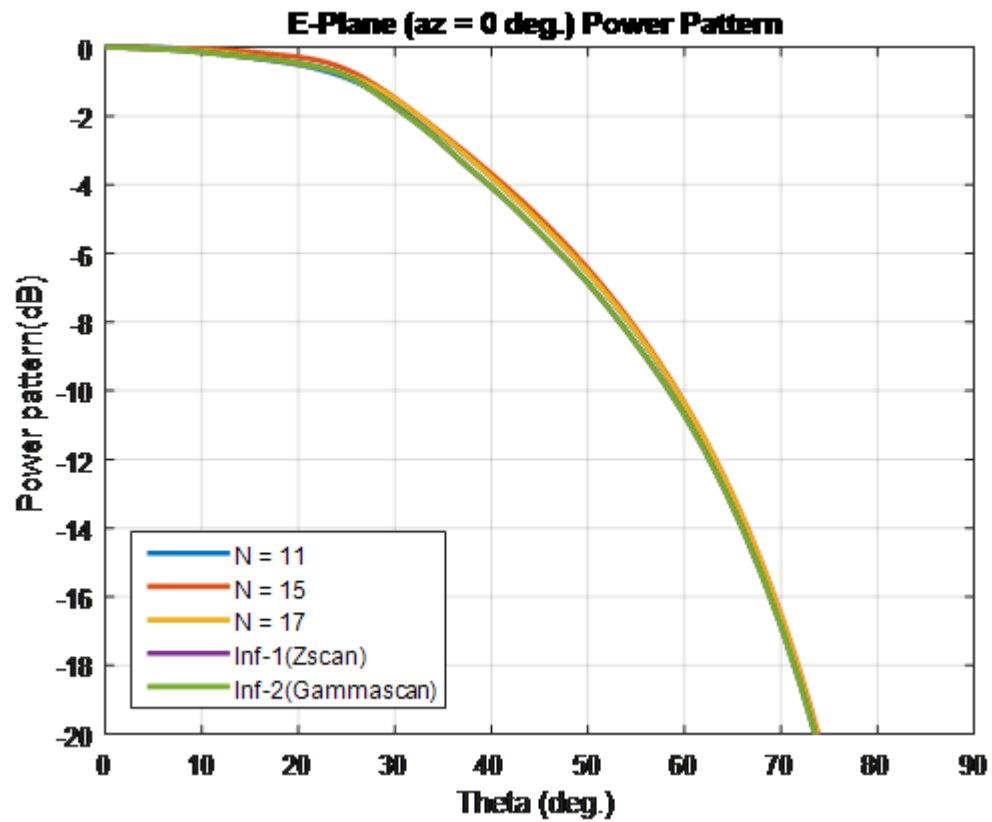

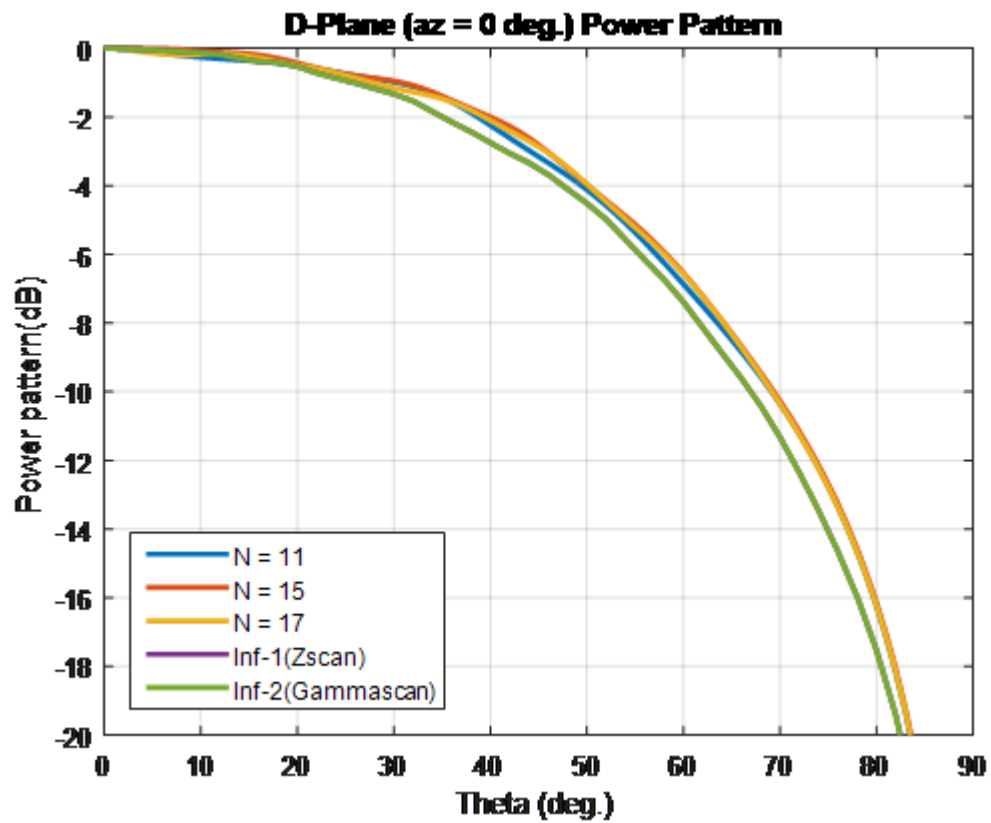

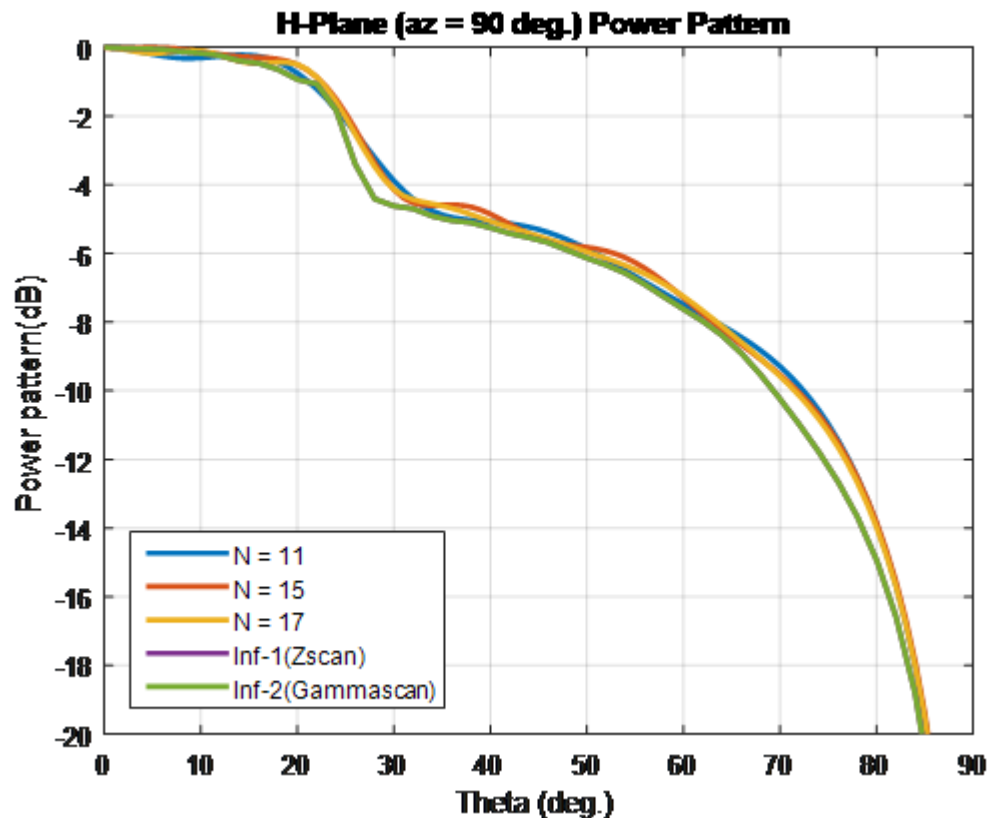

For finite arrays of size greater than  $10 \times 10$ , the scan element patterns in the E-, D-, and H-planes match the patterns of the infinite array scan element.

## Impact of Infinite Double Summation

As show in the Green's equations, the periodic Green's function has an infinite double summation in  $(m, n)$ . When performing infinite array analysis, the number of terms in the double summation affects the accuracy of the final solution. Higher number of terms results in better accuracy but increases computation time.

By default, Antenna Toolbox uses 10 terms for each summation term  $(m, n)$  to perform infinite array analysis. The total summation term length is  $2 \cdot 10 + 1$  (-10 to +10). To modify the number of terms, use the method `numSummationTerms`.

Higher number of terms are required if:

- You observe negative values for scan resistance for certain scan angles at certain frequencies.

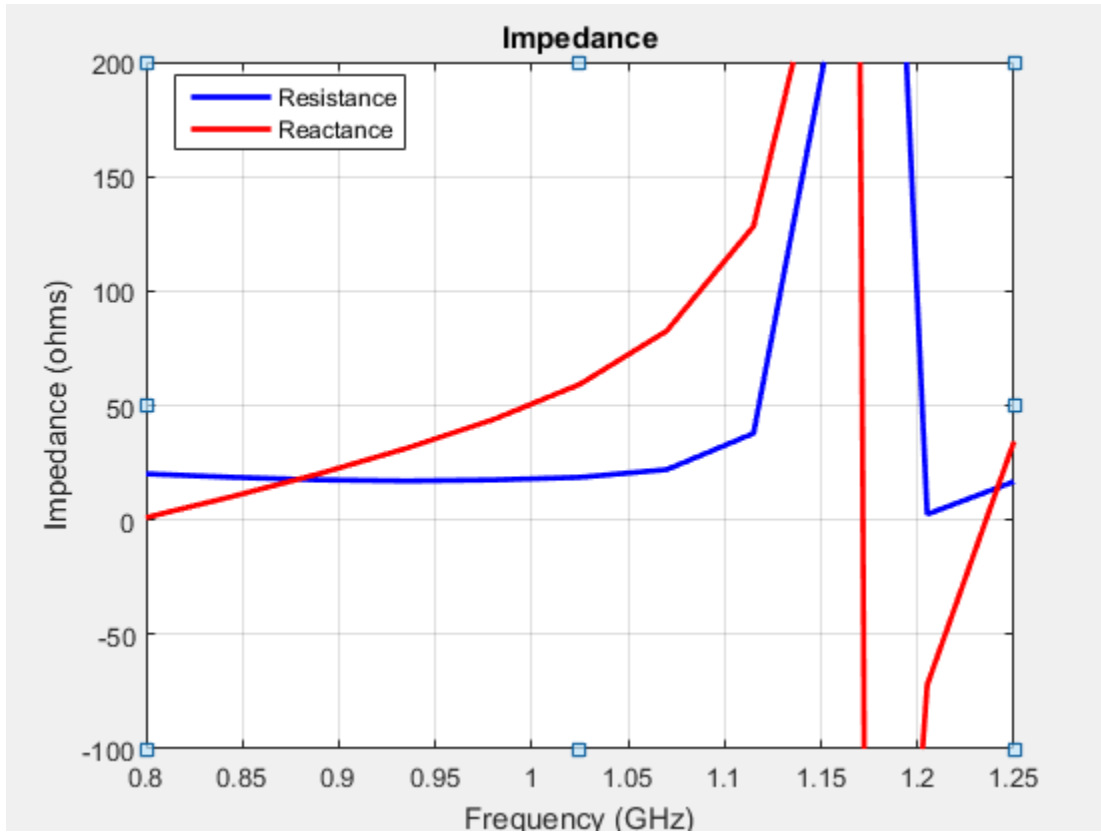

- You must investigate for convergence when scan impedance shows slow variations.

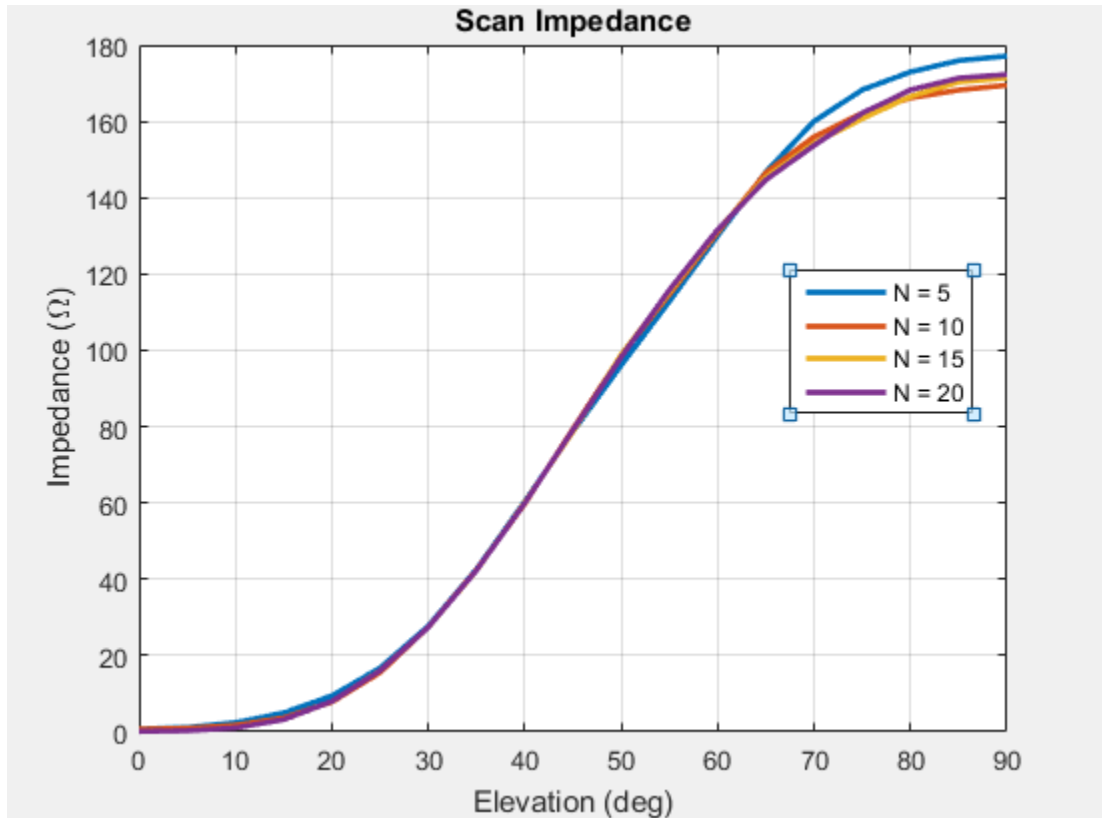

## References

- [1] Mailloux, R. J. *Phased Array Antenna Handbook*. Norwood, MA: Artech House. 2nd Edition. 2005.
- [2] Hansen, R. C. *Phased Array Antennas*. Hoboken, NJ: John Wiley & Sons Inc. 2nd Edition. 1998, pp. 221-313.
- [3] Allen, J. "Gain and impedance variation in scanned dipole arrays." *IRE Transactions on Antennas and Propagation*. Vol. 10, Number 5, September 1962, pp. 566-572.
- [4] Wasyliwskyj, W., and W. Kahn. "Efficiency as a measure of size of a phased-array antenna." *IEEE Transactions on Antennas and Propagation*. Vol. 21, Number 6, November 1973, pp. 879-884.

- [5] Holter, H., and H. Steyskal. "On the size requirement for finite phased-array models." *IEEE Transactions on Antennas and Propagation*. Vol. 50, Number 6, June 2002, pp. 836-840.

## Manipulate Array Elements

This example shows you how to control each individual element in a linear or rectangular array. You can use this technique to change the size and tilt of the antenna, or to model dead elements etc. with individual elements in an array.

### Define Dipole Array

Create a dipole antenna using the `dipole` class. To create a 5x5 dipole array, replicate the dipole antenna using a 5x5 matrix. Create a rectangular array using the dipole array as a single element.

```
d = dipole;
N = 5;
df = repmat(d,N)

df =
    5x5 dipole array with properties:

    Length: {25x1 cell}
    Width: {25x1 cell}
    FeedOffset: {25x1 cell}
    Tilt: {25x1 cell}
    TiltAxis: {25x1 cell}
    Load: {25x1 cell}

r = rectangularArray('Element',df);
show(r)
```

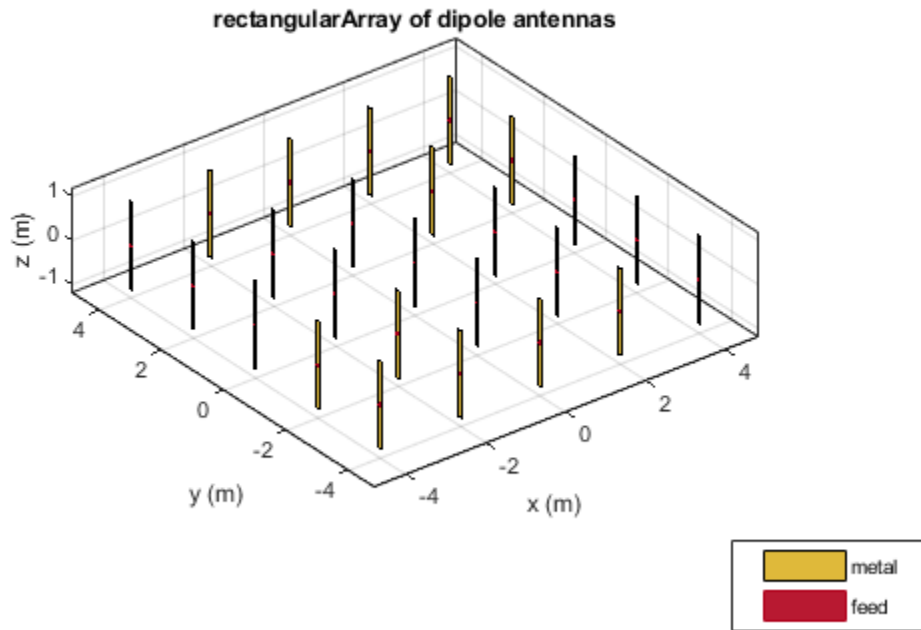

### Tilt Alternate Elements

Create a vector of alternate elements in the rectangular array.

```
S = [1:2:N*N];
```

Tilt the alternate elements in the array by 90 degrees about the y-axis.

```
for i = 1:25
    if any(S==i)
        r.Element(i).Tilt = 90;
        r.Element(i).TiltAxis = [0 1 0];
    end
end
show(r)
```



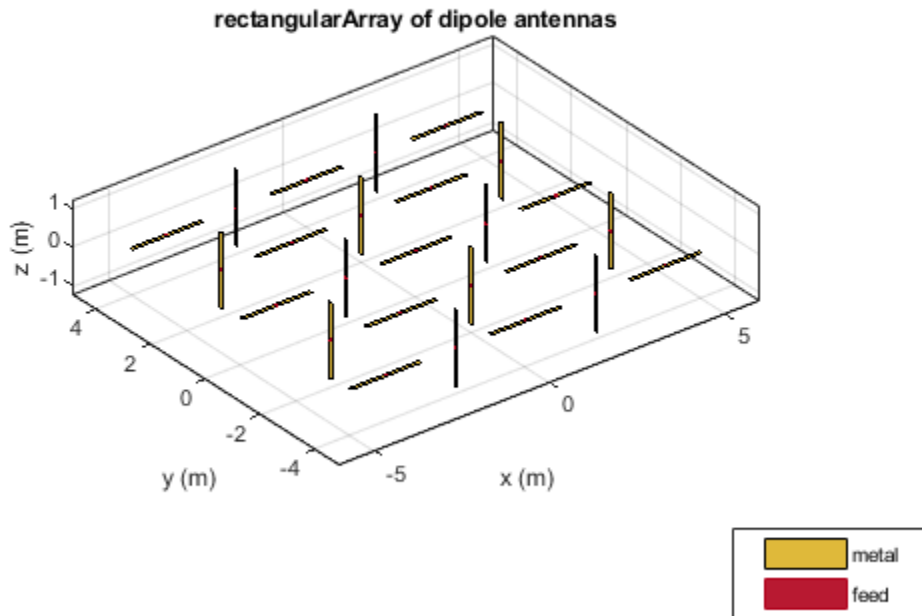

### Pattern of Rectangular Array

Plot the pattern of the array at 75 MHz.

```
pattern(r,75e6)
```

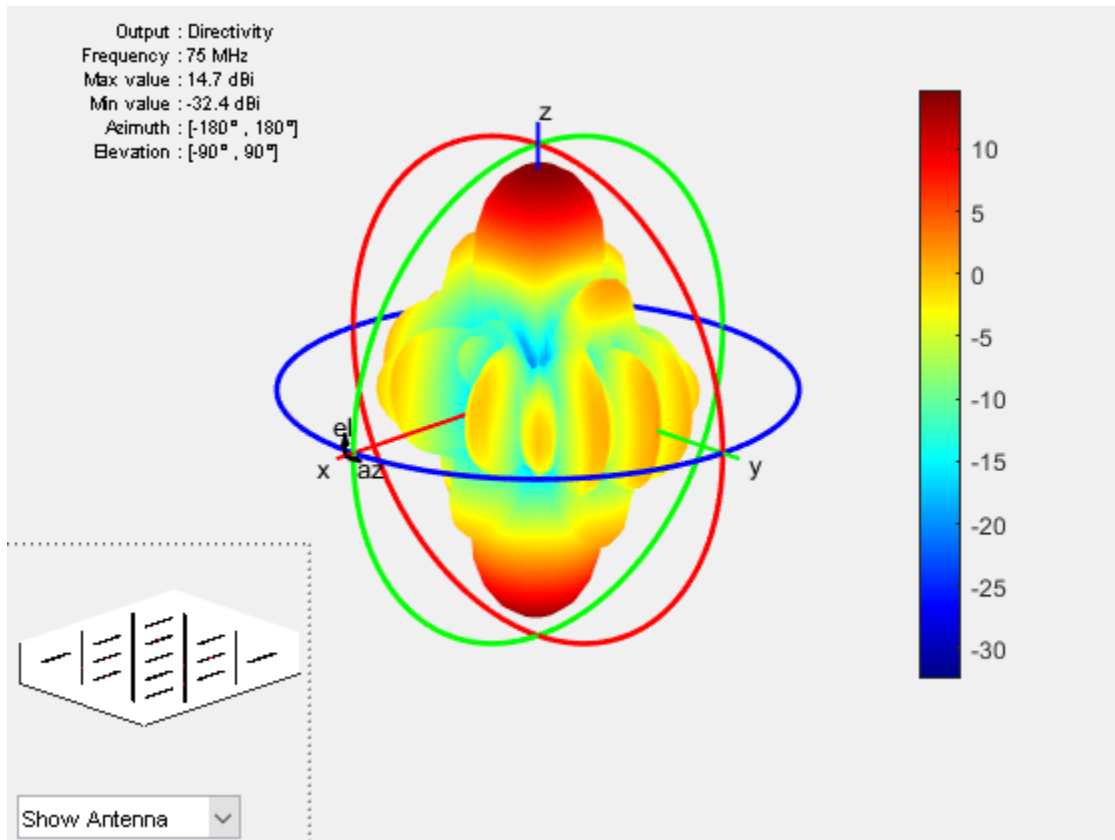

### Model Dead Elements

Antennas with a zero excitation voltage feed are called dead elements. By default, each element in an array is excited by an amplitude of 1 V.

$V_{\text{feed}} = \text{ones}(1, N \times N)$

$V_{\text{feed}} = 1 \times 25$

1 1 1 1 1 1 1 1 1 1 1 1 1 1 1

To model dead elements, set the voltage to zero for all horizontal elements. To control voltage, use the `AmplitudeTaper` property. This property is the excitation amplitude of the antennas in an array.

```
Vfeed(S) = 0
```

```
Vfeed = 1×25
```

```
    0    1    0    1    0    1    0    1    0    1    0    1    0    1
```

```
r.AmplitudeTaper = Vfeed
```

```
r =
```

```
  rectangularArray with properties:
```

```
      Element: [5×5 dipole]
      Size: [5 5]
      RowSpacing: 2
      ColumnSpacing: 2
      Lattice: 'Rectangular'
      AmplitudeTaper: [0 1 0 1 0 1 0 1 0 1 0 1 0 1 0 1 0 1 0 1 0]
      PhaseShift: 0
      Tilt: 0
      TiltAxis: [1 0 0]
```

Plot the radiation pattern of the array.

```
figure
pattern(r,75e6)
```

## 2 Array Concepts

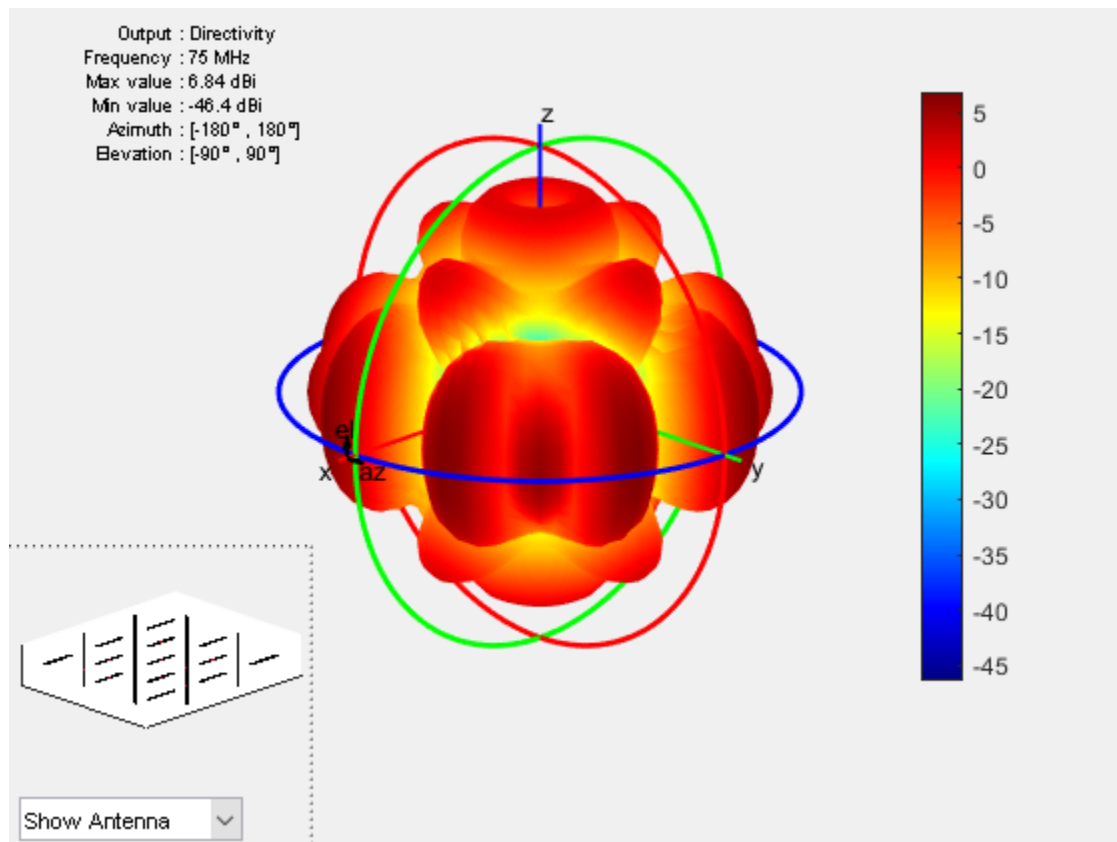

# Computational Techniques

---

- “Method of Moments Solver for Metal Structures” on page 3-2
- “Method of Moments Solver for Metal and Dielectric Structures” on page 3-11
- “Hybrid MoM-PO Method for Metal Antennas with Large Scatterers” on page 3-19

## Method of Moments Solver for Metal Structures

| In this section...                   |
|--------------------------------------|
| “MoM Formulation” on page 3-2        |
| “Neighbor Region” on page 3-6        |
| “Singularity Extraction” on page 3-7 |
| “Finite Arrays” on page 3-8          |
| “Infinite Array” on page 3-9         |

Method of Moments computation technique for metal antennas.

The first step in the computational solution of electromagnetic problems is to discretize Maxwell's equations. The process results in this matrix-vector system:

$$V = ZI$$

- $V$  — Applied voltage vector. This signal can be voltage or power applied to the antenna or an incident signal falling on the antenna.
- $I$  — Current vector that represents current on the antenna surface.
- $Z$  — Interaction matrix or impedance matrix that relates  $V$  to  $I$ .

Antenna Toolbox uses method of moments (MoM) to calculate the interaction matrix and solve system equations.

### MoM Formulation

The MoM formulation is split into three parts.

#### Discretization of Metals

Discretization enables the formulation from the continuous domain to the discrete domain. This step is called *meshing* in antenna literature. In the MoM formulation, the metal surface of the antenna is meshed into triangles.

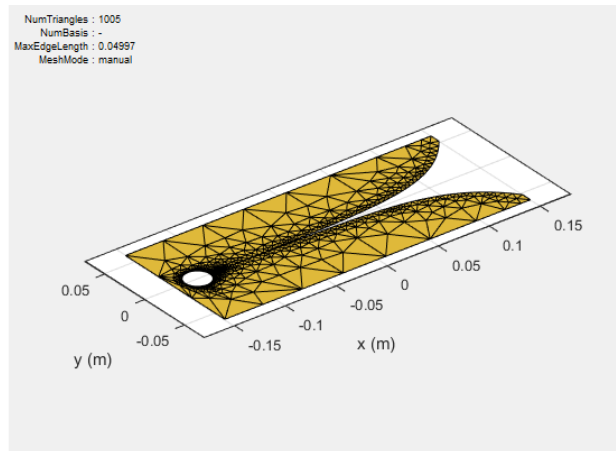
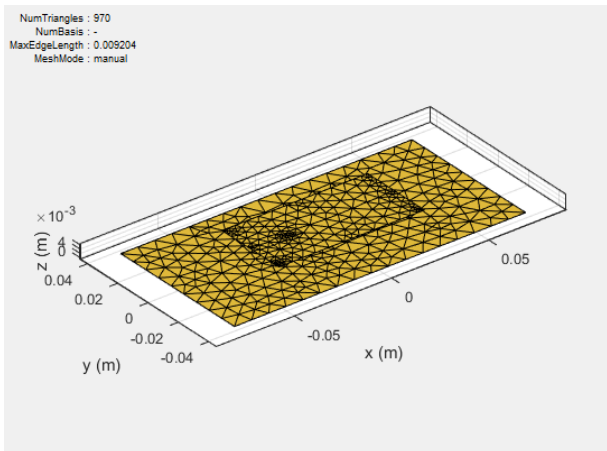

### Basis Functions

To calculate the surface currents on the antenna structure, you first define basis functions. Antenna Toolbox uses Rao-Wilton-Glisson (RWG) [2] basis functions. The arrows show the direction of current flow.

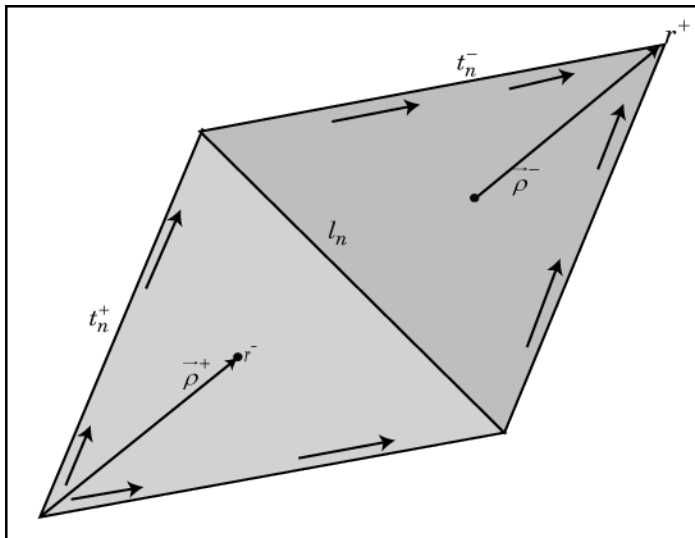

The basis function includes a pair of adjacent (not necessarily coplanar) triangles and resembles a small spatial dipole with linear current distribution. Each triangle is associated with a positive or negative charge.

For any two triangle patches,  $t_n^+$  and  $t_n^-$ , having areas  $A_n^+$  and  $A_n^-$ , and sharing common edge  $l_n$ , the basis function is

$$\vec{f}_n(\vec{r}) = \begin{cases} \frac{l_n}{2A_n^+} \vec{\rho}_n^{+S}, \vec{r} \in t_n^+ \\ \frac{l_n}{2A_n^-} \vec{\rho}_n^{-S}, \vec{r} \in t_n^- \end{cases}$$

- $\vec{\rho}_n^+ = \vec{r} - \vec{r}_n^+$  – Vector drawn from the free vertex of triangle  $t_n^+$  to observation point  $\vec{r}$
- $\vec{\rho}_n^- = \vec{r}_n^- - \vec{r}$  – Vector drawn from the observation point to the free vertex of the triangle  $t_n^-$

and

$$\nabla \cdot \vec{f}_n(\vec{r}) = \begin{cases} \frac{l_n}{A_n^+}, \vec{r} \in t_n^+ \\ -\frac{l_n}{A_n^-}, \vec{r} \in t_n^- \end{cases}$$

The basis function is zero outside the two adjacent triangles  $t_n^+$  and  $t_n^-$ . The RWG vector basis function is linear and has no flux (no normal component) through its boundary.

### Interaction Matrix

The interaction matrix is a complex dense symmetric matrix. It is a square  $N$ -by- $N$  matrix, where  $N$  is the number of basis functions, that is, the number of interior edges in the structure. A typical interaction matrix for a structure with 256 basis functions is shown:



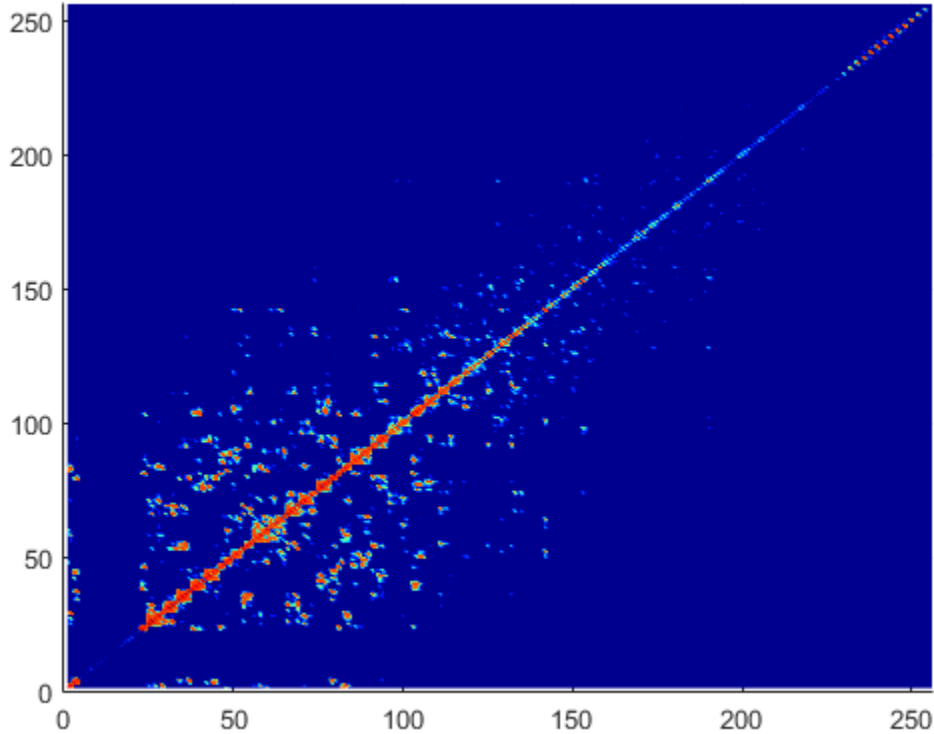

To fill out the interaction matrix, calculate the free-space Green's function between all basis functions on the antenna surface. The final interaction matrix equations are:

$$Z_{mn} = \left( \frac{j\omega\mu}{4\pi} \right) \int_S \int_S \vec{f}_m(\vec{r}) \cdot \vec{f}_m(\vec{r}') g d\vec{r}' d\vec{r} - \left( \frac{j}{4\pi\omega\epsilon} \right) \int_S \int_S (\nabla \cdot \vec{f}_m) (\nabla \cdot \vec{f}_m) g d\vec{r}' d\vec{r}$$

where

- $g(\vec{r}, \vec{r}') = \frac{\exp(-jk|\vec{r} - \vec{r}'|)}{|\vec{r} - \vec{r}'|}$  — Free-space Green's function

To calculate the interaction matrix, excite the antenna by a voltage of 1 V at the feeding edge. So the voltage vector has zero values everywhere except at the feeding edge. Solve the system of equations to calculate the unknown currents. Once you determine the unknown currents, you can calculate the field and surface properties of the antenna.

## Neighbor Region

From the interaction matrix plot, you observe that the matrix is diagonally dominant. As you move further away from the diagonal, the magnitude of the terms decreases. This behavior is same as the Green's function behavior. The Green's function decreases as the distance between  $r$  and  $r'$  increases. Therefore, it is important to calculate the region on the diagonal and close to the diagonal accurately.

This region on and around the diagonal is called *neighbor region*. The neighbor region is defined within a sphere of radius  $R$ , where  $R$  is in terms of triangle size. The size of a triangle is the maximum distance from the center of the triangle to any of its vertices. By default,  $R$  is twice the size of the triangle. For better accuracy, a higher-order integration scheme is used to calculate the integrals.

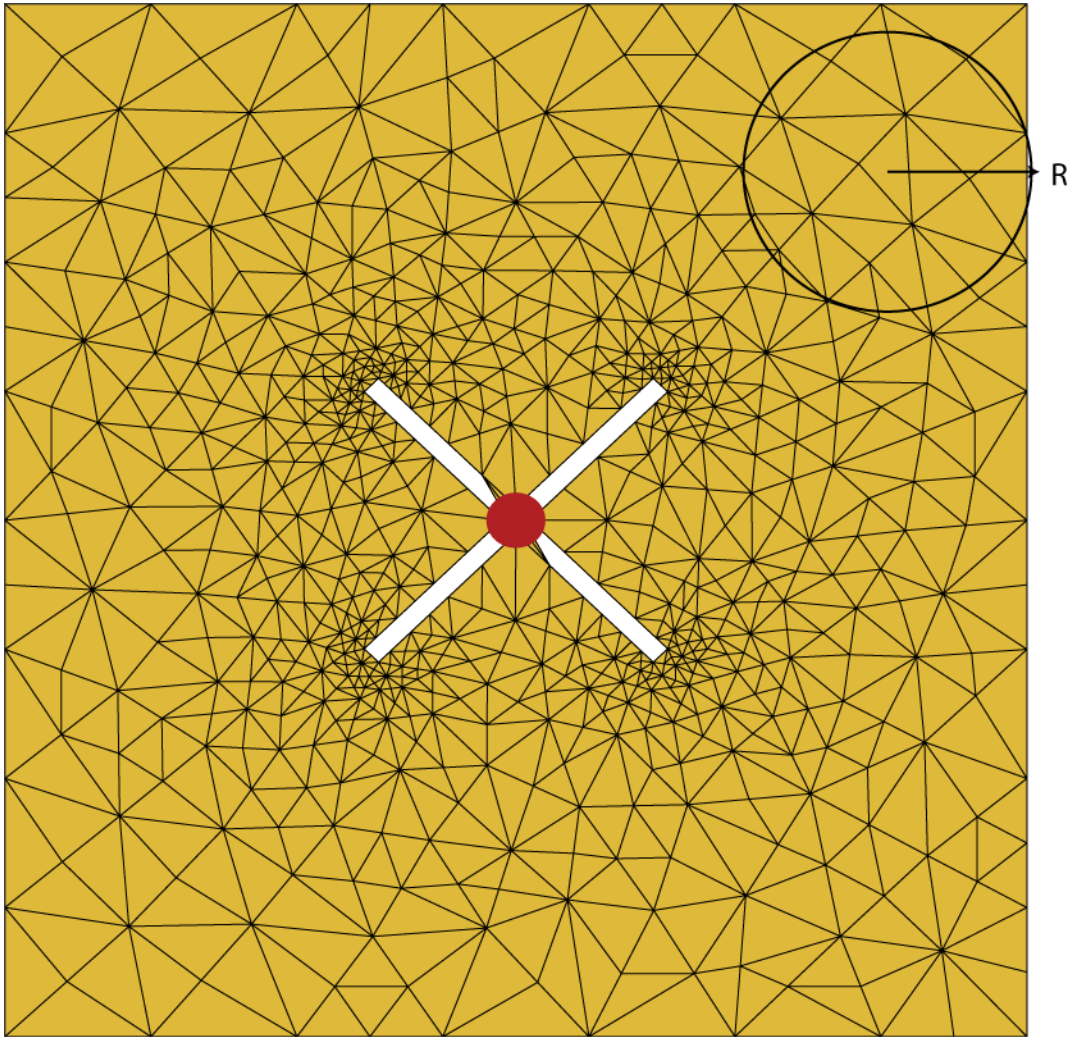

## Singularity Extraction

Along the diagonal,  $r$  and  $r'$  are equal and defines Green's function becomes singular. To remove the singularity, extraction is performed on these terms.

$$\int_{t_p} \int_{t_q} (\vec{\rho}_i \cdot \vec{\rho}'_j) g(\vec{r}, \vec{r}') ds' ds = \int_{t_p} \int_{t_q} \frac{(\vec{\rho}_i \cdot \vec{\rho}'_j)}{|\vec{r} - \vec{r}'|} ds' ds + \int_{t_p} \int_{t_q} \frac{(\exp(-jk|\vec{r} - \vec{r}'|) - 1)(\vec{\rho}_i \cdot \vec{\rho}'_j)}{|\vec{r} - \vec{r}'|} ds' ds$$

$$\int_{t_p} \int_{t_q} g(\vec{r}, \vec{r}') ds' ds = \int_{t_p} \int_{t_q} \frac{1}{|\vec{r} - \vec{r}'|} ds' ds + \int_{t_p} \int_{t_q} \frac{(\exp(-jk|\vec{r} - \vec{r}'|) - 1)}{|\vec{r} - \vec{r}'|} ds' ds$$

The two integrals on the right-hand side of the equations, called potential or static integrals are found using analytical results [3].

## Finite Arrays

The MoM formulation for finite arrays is the same as for a single antenna element. The main difference is the number of excitations (feeds). For finite arrays, the voltage vector is now a voltage matrix. The number of columns are equal to the number of elements in the array.

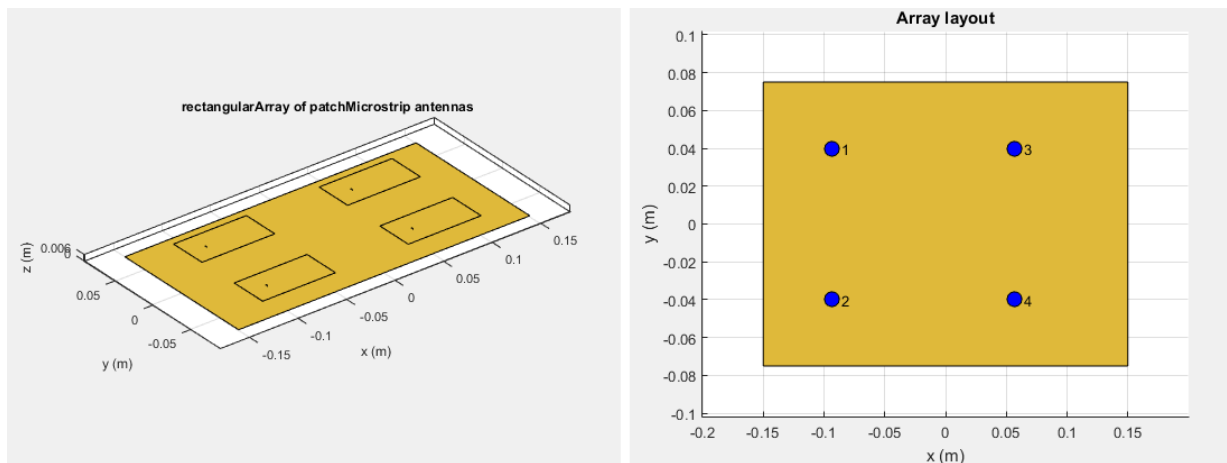

For example, the voltage vector matrix for a 2x2 array of rectangular patch antenna has four columns as each antenna can be excited separately.

## Infinite Array

To model an infinite array, you change the MoM to account for the infinite behavior. To do so you replace the free-space Green's functions with periodic Green's functions. The periodic Green's function is an infinite double summation.

| Green's Function                                    | Periodic Green's Function  |
|---|--|
| $g = \frac{e^{-jkR}}{R}$ $R =  \vec{r} - \vec{r}' $ | $g_{\text{periodic}} = \sum_{m=-\infty}^{\infty} \sum_{n=-\infty}^{\infty} e^{j\phi_{mn}} \frac{e^{-jkR_{mn}}}{R_{mn}}$ $R_{mn} = \sqrt{(x - x' - x_m)^2 + (y - y' - y_n)^2 + (z - z')^2}$ $\phi_{mn} = k(x_m \sin\theta \cos\phi + y_n \sin\theta \cos\phi)$ $x_m = m \cdot d_x, y_n = n \cdot d_y$ |

$d_x$  and  $d_y$  are the ground plane dimensions that define the  $x$  and  $y$  dimensions of the unit cell.  $\theta$  and  $\phi$  are the scan angles.

Comparing the two Green's functions, you observe an additional exponential term that is added to the infinite sum. The  $\phi_{mn}$  accounts for the scanning of the infinite array. The periodic Green's function also accounts for the effect of mutual coupling.

For more information see, "Infinite Arrays" on page 2-25.

## References

- [1] Harrington, R. F. *Field Computation by Moment Methods*. New York: Macmillan, 1968.
- [2] Rao, S. M., D. R. Wilton, and A. W. Glisson. "Electromagnetic scattering by surfaces of arbitrary shape." *IEEE. Trans. Antennas and Propagation*, Vol. AP-30, No. 3, May 1982, pp. 409-418.
- [3] Wilton, D. R., S. M. Rao, A. W. Glisson, D. H. Schaubert, O. M. Al-Bundak, and C. M. Butler. "Potential Integrals for uniform and linear source distribution on polygonal and polyhedral domains." *IEEE. Trans. Antennas and Propagation*. Vol. AP-30, No. 3, May 1984, pp. 276-281.
- [4] Balanis, C.A. *Antenna Theory. Analysis and Design*. 3rd Ed. New York: John Wiley & Sons, 2005.

## **See Also**

### **More About**

- “Infinite Arrays” on page 2-25

# Method of Moments Solver for Metal and Dielectric Structures

## In this section...

“MoM Formulation” on page 3-11

“Neighbor Region” on page 3-14

“Singularity Extraction” on page 3-16

“Finite Arrays” on page 3-16

“Infinite Array” on page 3-17

Method of Moments computation technique for metal and dielectric antennas.

Antennas using dielectric substrate consists of a metal part and a dielectric part. The first step in the computational solution of electromagnetic problems is to discretize Maxwell's equations. The process results in this matrix-vector system:

$$V = ZI$$

- $V$  — Applied voltage vector. This signal can be voltage or power applied to the antenna or an incident signal falling on the antenna.
- $I$  — Current vector that represents current on the antenna surface.
- $Z$  — Interaction matrix or impedance matrix that relates  $V$  to  $I$ . For calculating the interaction matrix, the effect of metal and dielectric parts in an antenna are taken separately.

Antenna Toolbox uses method of moments (MoM) to calculate the interaction matrix and solve system equations.

## MoM Formulation

The MoM formulation is split into three parts.

### Discretization of Dielectrics

Discretization enables the formulation from the continuous domain to the discrete domain. This step is called *meshing* in antenna literature. In the MoM formulation, the metal surface of the antenna is meshed into triangles and the dielectric volume is meshed into tetrahedrons.

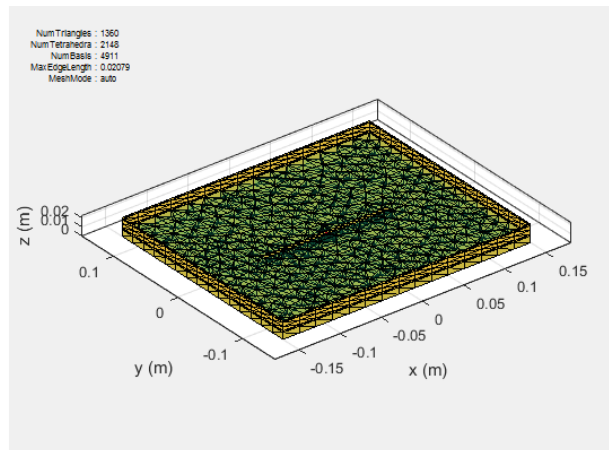
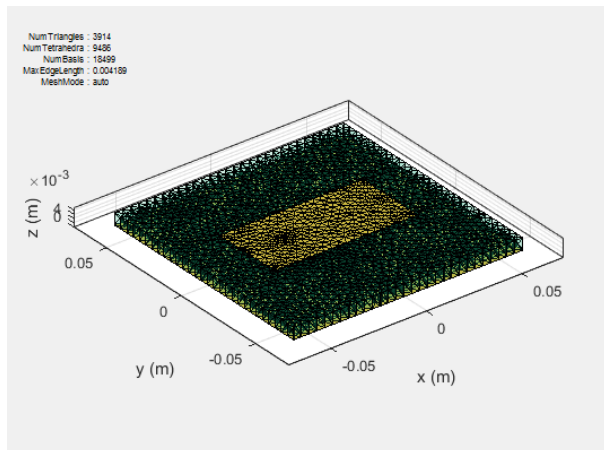

### Basis Functions

Basis functions are used to represent unknown quantities. In the case of antennas using dielectrics, the unknown quantities are the surface current on the metal structure and flux density due to dielectric volume. Antenna Toolbox uses Rao-Wilton-Glisson (RWG) [2] basis functions. For basis functions for a metal structure in an antenna refer, “Method of Moments Solver for Metal Structures” on page 3-2.

For the dielectric volume of the antenna, Antenna Toolbox uses a zeroth order edge basis function to model the flux density.

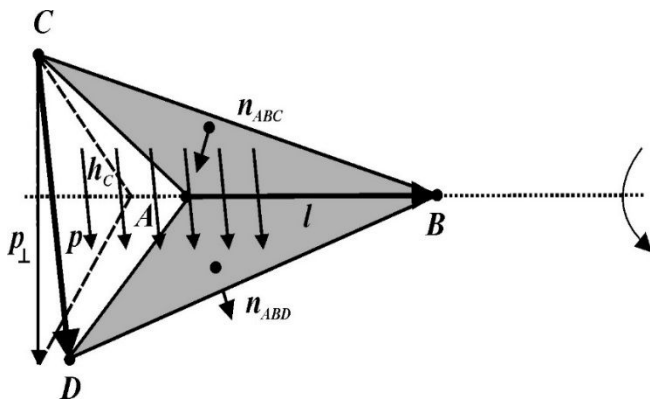



The figure shows an edge-based basis function. The vector variation is perpendicular to the base edge AB (or  $\vec{l}$ ). The vector of the edge CD (or  $\vec{p}$ ) defines the basis function. Within a tetrahedron, the basis function is a constant field given by

$$\vec{f} = c\vec{p}$$

- $c$  - normalization coefficient.
- $p$  - vector of the edge defining the basis function.

### Interaction Matrix

The interaction matrix is a complex dense symmetric matrix. For a metal-dielectric antenna, there are two sets of basis functions and four interactions. To fill out the interaction matrix, calculate the free-space Green's function between all the basis functions on the antenna surface. The final interaction matrix equations are:

- $Z_{MM}$  - metal to metal interaction. For a pure metal structure, you only calculate this symmetric square matrix.

$$Z_{mn}^{MM} = \left( \frac{j\omega\mu}{4\pi} \right) \int_S \int_S \vec{f}_m(\vec{r}) \cdot \vec{f}_n(\vec{r}') g d\vec{r}' d\vec{r} - \left( \frac{j}{4\pi\omega\epsilon} \right) \int_S \int_S \left( \nabla \cdot \vec{f}_m \right) \left( \nabla \cdot \vec{f}_n \right) g d\vec{r}' d\vec{r}$$

- $Z_{DD}$  - dielectric to dielectric interaction. For pure dielectric structures, you only calculate this symmetric square matrix.

$$\begin{aligned} \widehat{Z}_{mn}^{DD} &= \sum_{p=1}^P \sum_{p'=1}^{P'} \frac{K_p}{\epsilon_p V_D} \int \vec{f}_{mp}(\vec{r}) \cdot \vec{f}_{np'}(\vec{r}') d\vec{r} \\ &- \frac{\omega^2 \mu_0}{4\pi} \sum_{p=1}^P \sum_{p'=1}^{P'} K_p K_{p'} \int_{V_D} \int_{V_{D'}} g(\vec{r}, \vec{r}') \vec{f}_{mp}(\vec{r}) \cdot \vec{f}_{np'}(\vec{r}') d\vec{r} d\vec{r}' \\ &- \frac{1}{4\pi\epsilon_0} \sum_{q=1}^Q \sum_{q'=1}^{Q'} \widehat{K}_q \widehat{K}_{q'} \int_{\Omega_q} \int_{\Omega_{q'}} g(\vec{r}, \vec{r}') f_{\perp mq}(\vec{r}) f_{\perp nq'}(\vec{r}') d_s d_{s'} \quad m, n = 1, \dots, N \end{aligned}$$

- $Z_{MD}$  and  $Z_{DM}$  - These matrices calculate the interaction between metal and dielectric. This matrix is not a symmetrical square matrix.

$$\begin{aligned}
 Z_{mn}^{MD} &= -\frac{\omega^2 \mu_0}{4\pi} \sum_{p=1}^2 \sum_{p'=1}^{P'} K_p \int_t \int_{V_D'} \vec{f}_n^M(\vec{r}) \cdot \vec{f}_{mp'}(\vec{r}') g(\vec{r}, \vec{r}') d\vec{r}' d_s \\
 &\quad - \frac{1}{4\pi \epsilon_0} \sum_{p=1}^2 \sum_{q=1}^Q \widehat{K}_q \int_{t_D} \int_{\Omega_q'} (\nabla_s \cdot \vec{f}_n^M(\vec{r})) f_{\perp mq}(\vec{r}') g(\vec{r}, \vec{r}') d\Omega' d_s \\
 &\quad m = 1, \dots, N_D; n = 1, \dots, N_M \\
 \\
 Z_{mn}^{DM} &= -\frac{j\omega \mu_0}{4\pi} \sum_{p=1}^2 \sum_{p'=1}^{P'} K_{p'} \int_{V_D} \int_{S_{D'}} \vec{f}_{np}(\vec{r}) \cdot \vec{f}_m^M(\vec{r}') g(\vec{r}, \vec{r}') d_s d\vec{r}' \\
 &\quad + \frac{1}{4\pi \epsilon_0 \omega} \sum_{p=1}^2 \sum_{q=1}^Q \widehat{K}_q \int_{\Omega_q} \int_{S_{D'}} f_{\perp np}(\vec{r}) \cdot (\nabla_s \cdot \vec{f}_m^M(\vec{r}')) g(\vec{r}, \vec{r}') d_s d\Omega \\
 &\quad m = 1, \dots, N_D; n = 1, \dots, N_M
 \end{aligned}$$

where

- $g(\vec{r}, \vec{r}') = \frac{\exp(-jkR)}{R}$ ,  $R = |\vec{r} - \vec{r}'|$  is the free space Green's function.
- $K = \frac{\widehat{\epsilon}^{\pm} - \epsilon_0}{\widehat{\epsilon}^{\pm}}$  is the complex dielectric constant within every tetrahedron.
- $\widehat{K}_q = K_+ - K_-$  is the differential contrast on every face of the tetrahedron.

For a composite metal structure, you must calculate all four matrices.

## Neighbor Region

The figure shows a typical interaction matrix for a metal structure  $Z_{MM}$  with 256 basis functions.

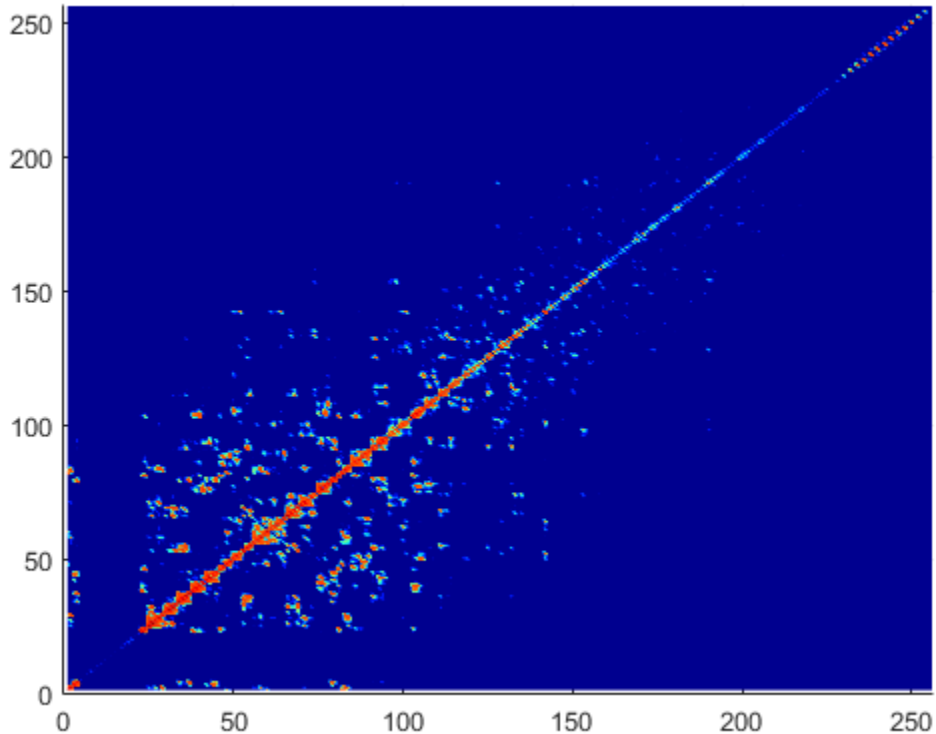

From the interaction matrix plot, you observe that the matrix is diagonally dominant. The dielectric interaction matrix is also diagonally dominant. As you move further away from the diagonal, the magnitude of the terms decreases. This behavior is same as the Green's function behavior. The Green's function decreases as the distance between  $r$  and  $r'$  increases. Therefore, it is important to calculate the region on the diagonal and close to the diagonal accurately.

This region on and around the diagonal is called *neighbor region*. For a metal-dielectric antenna, the neighborhood region is based on the average size of the tetrahedron.

For neighboring region details for metal antennas refer, "Method of Moments Solver for Metal Structures" on page 3-2.

## Singularity Extraction

Along the diagonal,  $r$  and  $r'$  are identical and the defined Green's function becomes singular. To remove the singularity, extraction is performed on these terms. The equations for the singularity extraction of the  $Z_{MM}$  matrix are:

$$\int_{t_p} \int_{t_q} (\vec{\rho}_i \cdot \vec{\rho}'_j) g(\vec{r}, \vec{r}') ds' ds = \int_{t_p} \int_{t_q} \frac{(\vec{\rho}_i \cdot \vec{\rho}'_j)}{|\vec{r} - \vec{r}'|} ds' ds + \int_{t_p} \int_{t_q} \frac{(\exp(-jk|\vec{r} - \vec{r}'|) - 1)(\vec{\rho}_i \cdot \vec{\rho}'_j)}{|\vec{r} - \vec{r}'|} ds' ds$$

$$\int_{t_p} \int_{t_q} g(\vec{r}, \vec{r}') ds' ds = \int_{t_p} \int_{t_q} \frac{1}{|\vec{r} - \vec{r}'|} ds' ds + \int_{t_p} \int_{t_q} \frac{(\exp(-jk|\vec{r} - \vec{r}'|) - 1)}{|\vec{r} - \vec{r}'|} ds' ds$$

The two integrals on the right-hand side of the equations, called potential or static integrals are found using analytical results [3].

The equations for the singularity extraction of the  $Z_{DD}$  matrix are:

$$\int_{V_D} \int_{V_{D'}} g(\vec{r}, \vec{r}') d\vec{r} d\vec{r}' = \int_{V_D} \int_{V_q} \frac{1}{|\vec{r} - \vec{r}'|} d\vec{r} d\vec{r}' + \int_{V_D} \int_{V_q} \frac{(\exp(-jk|\vec{r} - \vec{r}'|) - 1)}{|\vec{r} - \vec{r}'|} d\vec{r} d\vec{r}'$$

$$\int_{\Omega_q} \int_{\Omega_{q'}} g(\vec{r}, \vec{r}') d\Omega d\Omega' = \int_{\Omega_D} \int_{\Omega_q} \frac{1}{|\vec{r} - \vec{r}'|} d\Omega d\Omega' + \int_{S_D} \int_{S_q} \frac{(\exp(-jk|\vec{r} - \vec{r}'|) - 1)}{|\vec{r} - \vec{r}'|} d\Omega d\Omega'$$

## Finite Arrays

The MoM formulation for finite arrays is the same as for a single antenna element. The main difference is the number of excitations (feeds). For finite arrays, the voltage vector is now a voltage matrix. The number of columns are equal to the number of elements in the array.

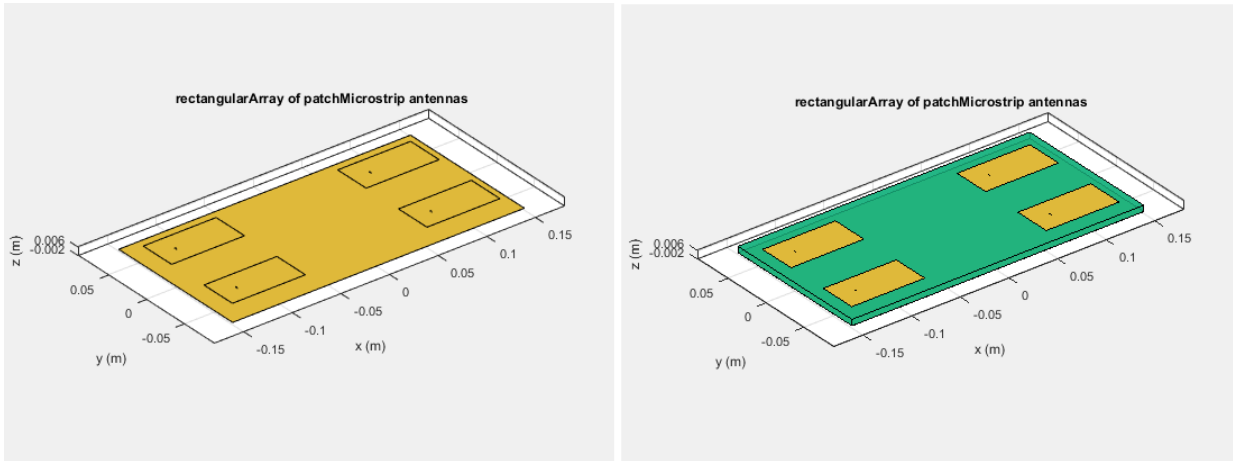

For example, the voltage vector matrix for a 2x2 array of rectangular patch antenna (with and without dielectric substrate) has four columns as each antenna can be excited separately.

## Infinite Array

To model an infinite array, you change the MoM to account for the infinite behavior. To do so, you replace the free-space Green's functions with periodic Green's functions. The periodic Green's function is an infinite double summation.

| Green's Function                                    | Periodic Green's Function  |
|---|--|
| $g = \frac{e^{-jkR}}{R}$ $R =  \vec{r} - \vec{r}' $ | $g_{\text{periodic}} = \sum_{m=-\infty}^{\infty} \sum_{n=-\infty}^{\infty} e^{j\phi_{mn}} \frac{e^{-jkR_{mn}}}{R_{mn}}$ $R_{mn} = \sqrt{(x - x' - x_m)^2 + (y - y' - y_n)^2 + (z - z')^2}$ $\phi_{mn} = k(x_m \sin\theta \cos\varphi + y_n \sin\theta \cos\varphi)$ $x_m = m \cdot d_x, y_n = n \cdot d_y$ |

$d_x$  and  $d_y$  are the ground plane dimensions that define the x and y dimensions of the unit cell.  $\theta$  and  $\varphi$  are the scan angles.

Comparing the two Green's functions, you observe an additional exponential term that is added to the infinite sum. The  $\Phi_{mn}$  accounts for the scanning of the infinite array. The periodic Green's function also accounts for the effect of mutual coupling.

For more information see, "Infinite Arrays" on page 2-25.

## References

- [1] Harrington, R. F. *Field Computation by Moment Methods*. New York: Macmillan, 1968.
- [2] Rao, S. M., D. R. Wilton, and A. W. Glisson. "Electromagnetic scattering by surfaces of arbitrary shape." *IEEE. Trans. Antennas and Propagation*, Vol. AP-30, No. 3, May 1982, pp. 409-418.
- [3] Wilton, D. R., S. M. Rao, A. W. Glisson, D. H. Schaubert, O. M. Al-Bundak. and C. M. Butler. "Potential Integrals for uniform and linear source distribution on polygonal and polyhedral domains." *IEEE. Trans. Antennas and Propagation*. Vol. AP-30, No. 3, May 1984, pp. 276-281.
- [4] Balanis, C.A. *Antenna Theory. Analysis and Design*. 3rd Ed. New York: John Wiley & Sons, 2005.

## See Also

### More About

- "Infinite Arrays" on page 2-25
- "Method of Moments Solver for Metal Structures" on page 3-2

## Hybrid MoM-PO Method for Metal Antennas with Large Scatterers

### In this section...

“Subdomain RWG Basis Functions and Extra Dimensions” on page 3-19

“MoM Region and PO Region” on page 3-21

“MoM Solution and PO Solution” on page 3-22

“Finding ZPO” on page 3-23

“Direct Solution Method” on page 3-24

Hybrid method of moments (MoM) physical optics (PO) computational technique in Antenna Toolbox allows you to model antennas near large scatterers such as parabolic reflectors. The antenna element is modeled using MoM while the effect of electrically large structures is considered using PO.

### Subdomain RWG Basis Functions and Extra Dimensions

The familiar Rao Wilton Glisson (RWG) basis functions on triangles are based on [2].

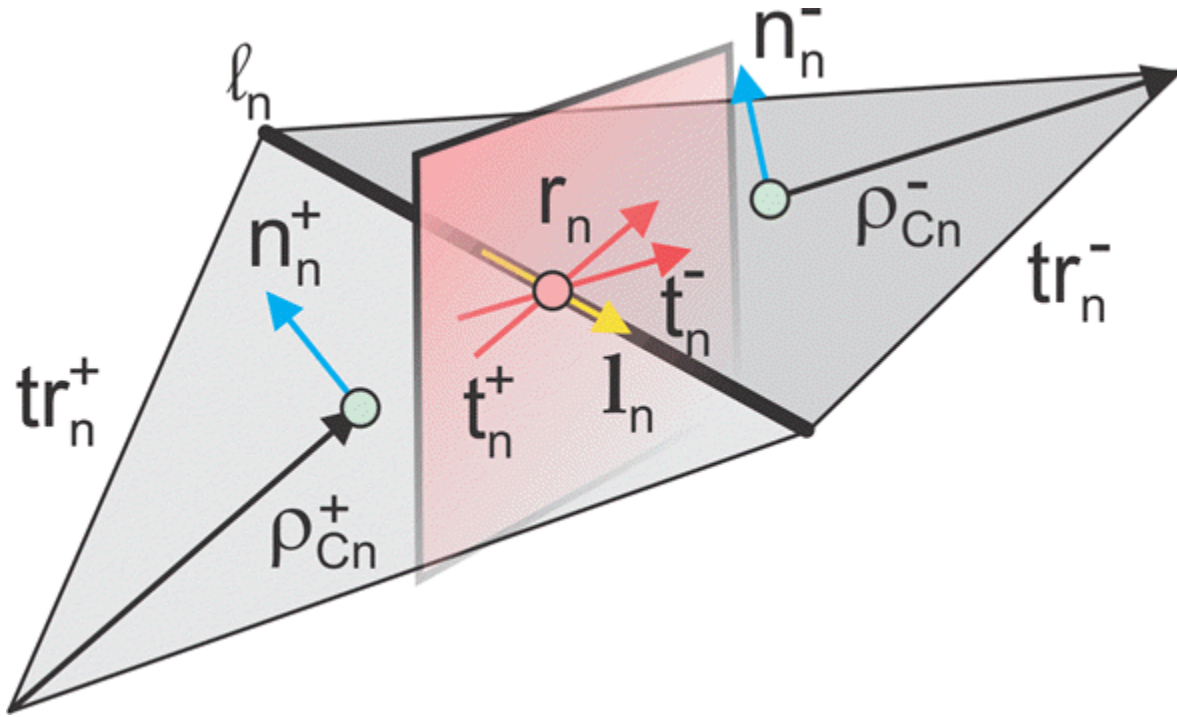

In the image, for two arbitrary triangular patches  $tr_n^+$  and  $tr_n^-$  having areas  $A_n^+$  and  $A_n^-$  and sharing a common edge  $l_n$  the basis functions has the form

$$\vec{f}_n(\vec{r}) = \begin{cases} \frac{l_n}{2A_n^+} \vec{\rho}_n^+ & \vec{r} \text{ in } tr_n^+ \\ \frac{l_n}{2A_n^-} \vec{\rho}_n^- & \vec{r} \text{ in } tr_n^- \end{cases} \quad (1)$$

where  $\vec{\rho}_n^+ = \vec{r} - \vec{r}_n^+$  is the vector drawn from the free vertex of the triangle  $tr_n^+$  to the observation point  $\vec{r}$ ;  $\vec{\rho}_n^- = \vec{r}_n^- - \vec{r}$  is the vector drawn from the observation point to the free vertex of the triangle  $tr_n^-$ . The basis function is zero outside the two adjacent triangles. The RWG vector basis function is linear and has no flux (that is, has no normal component) through its boundary.



From [1], along with the standard definition, this method requires two unit normal vectors  $\vec{n}_n^\pm$  and two-unit vectors  $\vec{t}_n^\pm$  also shown in the figure. Vector  $\vec{t}_n^+$  is the plane of triangle  $tr_n^+$ ; both vectors are perpendicular to the edge  $l_n$ . They are defined at the center of edge  $l_n$ , which are denoted by  $\vec{l}_n^\pm$ . Directions of  $\vec{t}_n^\pm$  are also shown in the figure. This technique assumes that the normal vectors are properly (angle between adjacent  $\vec{n}_n^\pm$  must be less than 180 degrees) and uniquely defined. Specific vector orientation (e.g. outer or inner normal vectors) does not matter. We then form two cross product vectors  $\vec{l}_n^\pm$ ,

$$\vec{l}_n^\pm = \vec{t}_n^\pm \times \vec{n}_n^\pm \quad (2)$$

and establish that both such unit vectors directed along the edge are identical,

$$\vec{l}_n^\pm = \vec{l}_n^- = \vec{l}_n \quad (3)$$

Only vector  $\vec{l}_n$  is eventually needed.

## MoM Region and PO Region

The surface current density,  $\vec{J}(\vec{r})$ , on the entire metal surface is expanded into  $N$  RWG basis functions. However, a part of such basis functions belongs to the MoM region (or "exact region") while another part will belong to the PO region (or "approximate region"). These basis functions (or regions) can overlap and be arbitrarily distributed in space (not necessarily be contiguous). The method assumes that  $N_{MoM}$  basis functions from the MoM region up front in the list and  $N_{PO}$  basis functions for the PO region afterward. Therefore, you have ( $N_{PO} + N_{MoM} = N$ )

$$\vec{J}(\vec{r}) = \sum_{n=1}^{N_{MoM}} I_n^{MoM} \vec{f}_n(\vec{r}), \quad \vec{J}(\vec{r}) = \sum_{n=1}^{N_{PO}} I_n^{PO} \vec{f}_{n+N_{MoM}}(\vec{r}) \quad (4)$$

### MoM Solution and PO Solution

If there is no PO region, you can solve the entire problem using the MoM with single square MoM system matrix  $\check{Z}$ , which may be subdivided into 4 matrices as shown.

$$\check{Z} = \begin{pmatrix} \check{Z}_{11} & \check{Z}_{12} \\ \check{Z}_{21} & \check{Z}_{22} \end{pmatrix}, \dim(\check{Z}_{11}) = N_{MoM} \times N_{MoM}, \dim(\check{Z}_{12}) = N_{MoM} \times N_{PO} \quad (5)$$

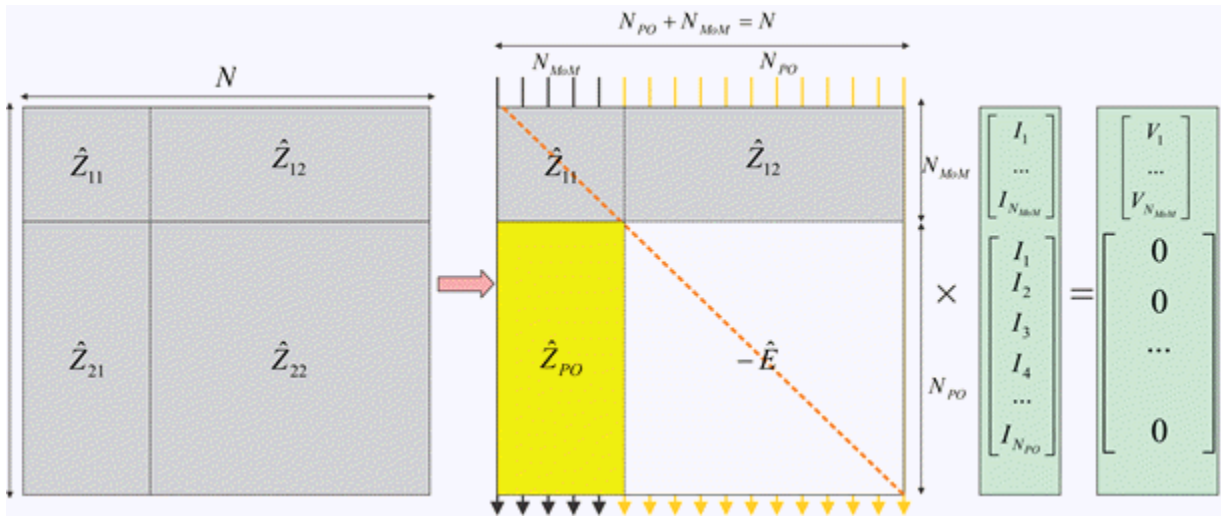

The figure shows the matrix interpretation of the hybrid MoM-PO solution and its comparison with plain MoM solution. The method assumes the antenna feeds gives the vector,  $\vec{V}$  that describes the excitation, which belongs to the MoM region only.

The hybrid solution keeps submatrices  $\check{Z}_{11}$  and  $\check{Z}_{12}$ . In other words, the method solves the standard system of the linear equations for the MoM region where radiation from the PO region via  $\check{Z}_{12}$  is considered.

The hybrid solution ignores the submatrices,  $\check{Z}_{22}$  entirely. Here, the currents in the PO region do not interact with each other. They are found via the radiated magnetic field,

$\vec{H}(\vec{r})$ , from the MoM region, using PO approximation [1]. A new matrix describes this operation,  $\check{Z}_{PO}$ , and negative identity matrix,  $E$ , which replaces  $\check{Z}_{22}$ .

## Finding ZPO

The suitable PO approximation has the form [1]

$$\vec{J}(\vec{r}) = 2\delta(\vec{r})[\vec{n}(\vec{r}) \times \vec{H}(\vec{r})] \quad (6)$$

where  $\delta$  accounts for the shadowing effects. If the observation point lies in the shadow region,  $\delta$  must be zero. Otherwise it equals  $\pm 1$  depending on the direction of incidence with respect to the orientation normal vector  $\vec{n}(\vec{r})$ . Using second Eq.(4) yields:

$$\sum_{n=1}^{N_{PO}} I_n^{PO} \vec{f}_{n+N_{MoM}}(\vec{r}) = 2\delta(\vec{r})[\vec{n}(\vec{r}) \times \vec{H}(\vec{r})] \quad (7)$$

Reference [1] outlines an elegant way to express unknowns  $I_n^{PO}$  explicitly, using an interesting variation of the collocation method. First, we consider a collocation point that tends to the edge center  $\vec{r}_{n+N_{MoM}}$  of a certain basis function  $\vec{f}_{n+N_{MoM}}(\vec{r})$  and is in its plus triangle. We then multiply Eq. (7) by vector  $\vec{t}_{n+N_{MoM}}^+$ . Since the normal component of the basis function under interest at the edge is one and all other basis functions sharing the same triangle have no normal component at this edge, the result becomes

$$I_n^{PO} = 2\delta(\vec{r}_{n+N_{MoM}}) \vec{t}_{n+N_{MoM}}^+ \cdot \left[ \vec{n}_{n+N_{MoM}}^+ \times \vec{H}(\vec{r}_{n+N_{MoM}}) \right] \quad (8a)$$

Repeat the same operation with the minus triangle and obtain

$$I_n^{PO} = 2\delta(\vec{r}_{n+N_{MoM}}) \vec{t}_{n+N_{MoM}}^- \cdot \left[ \vec{n}_{n+N_{MoM}}^- \times \vec{H}(\vec{r}_{n+N_{MoM}}) \right] \quad (8b)$$

Add both Eqs. (8a) and (8b) together, divide the result by two, and transform the triple vector product to obtain

$$I_n^{PO} = 2\delta(\vec{r}_{n+N_{MoM}}) \vec{H}(\vec{r}_{n+N_{MoM}}) \cdot \left( \left[ \vec{t}_{n+N_{MoM}}^+ \times \vec{n}_{n+N_{MoM}}^+ \right] + \left[ \vec{t}_{n+N_{MoM}}^- \times \vec{n}_{n+N_{MoM}}^- \right] \right) / 2 \quad (9)$$

Therefore, according to Eqs. (2) and (3),

$$I_n^{PO} = 2\delta(\vec{r}_{n+N_{MoM}}) \vec{H}(\vec{r}_{n+N_{MoM}}) \cdot \vec{l}_{n+N_{MoM}} \quad (10)$$

To complete the derivation, the H-field radiated by the MoM region is always written in the form

$$\vec{H}(\vec{r}) = \sum_{n=1}^{N_{MoM}} \vec{C}_n(\vec{r}) I_n^{MoM} \quad (11)$$

where  $\vec{C}_n(r)$  are given by individual basis function contributions. In the simplest case, every such contribution is the dipole radiation [3]. Substitution of Eq. (11) into Eq. (10) yields

$$I_n^{PO} = \sum_{m=1}^{N_{MoM}} \check{Z}_{POmn} I_m^{MoM} \quad (12)$$

$$\check{Z}_{POmn} = 2\delta(\vec{r}_{n+N_{MoM}}) \vec{C}_n(\vec{r}_{n+N_{MoM}}) \cdot \vec{l}_{m+N_{MoM}} \quad m = 1, \dots, N_{PO}, \quad n = 1, \dots, N_{MoM}$$

## Direct Solution Method

According to the second figure, the coupled system of equations has the form

$$\check{Z}_{11} \vec{I}^{MoM} + \check{Z}_{12} \vec{I}^{PO} = \vec{V} \quad (13)$$

$$\vec{I}^{PO} = \check{Z}_{PO} \vec{I}^{MoM}$$

The direct solution method results in the substitution of the expression for the PO current into the first equation,

$$(\check{Z}_{11} + \check{Z}_{12} \check{Z}_{PO}) \vec{I}^{MoM} = \vec{V} \quad (14)$$

## References

- [1] U. Jakobus and F. M. Landstorfer, "Improved PO-MM Formulation for Scattering from Three-Dimensional Perfectly Conducting Bodies of Arbitrary Shape," *IEEE Trans. Antennas and Propagation*, vol. AP-43, no. 2, pp. 162-169, Feb. 1995.
- [2] S. M. Rao, D. R. Wilton, and A. W. Glisson, "Electromagnetic scattering by surfaces of arbitrary shape," *IEEE Trans. Antennas and Propagation*, vol. AP-30, no. 3, pp. 409-418, May 1982.
- [3] S. Makarov, *Antenna and EM Modeling in MATLAB*, Wiley, New York, 2002.

## See Also



# RF Propagation

---

- “Site Viewer” on page 4-2
- “Troubleshooting Site Viewer” on page 4-10
- “Access Basemaps and Terrain in Site Viewer” on page 4-12
- “Access TIREM Software” on page 4-14

# Site Viewer

| In this section...  |
|---|
| “Introduction” on page 4-2  |
| “Dimension Picker” on page 4-3                                    |
| “Basemaps” on page 4-4  |
| “View Latitude and Longitude Coordinates of Location” on page 4-8 |

## Introduction

Transmitter and receiver site for RF propagation visualization involves a map display called Site Viewer. You can use the **Home** button to view the default home location of Site Viewer.



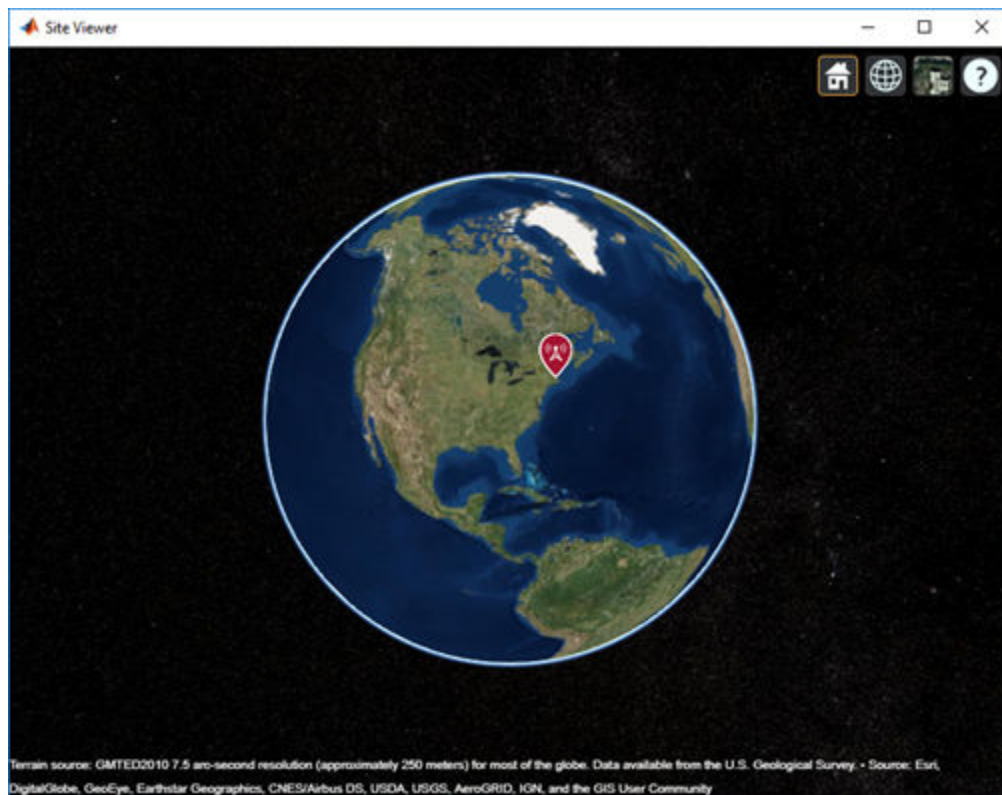

Site Viewer includes in-canvas pan, zoom, and rotation. Site Viewer can have only one window open at a time.

Site Viewer is a 3-D map display and requires hardware graphics support for WebGL™.

## Dimension Picker

The dimension picker offers three choices: 3-D, 2-D and Columbus View.

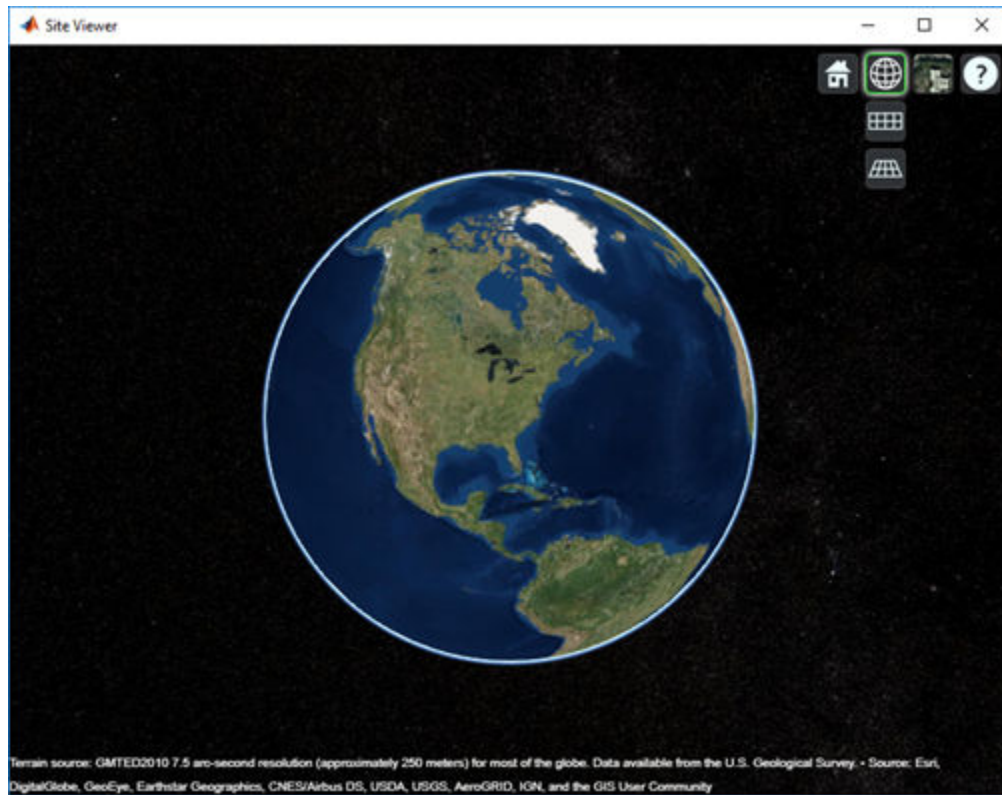

- 3-D View - Provides a smooth globe. This is the default view.
- 2-D View - Provides a flat map in Mercator projection.
- Columbus View - Provides a flat map in Mercator projection that allows tilt and rotation.

### **Basemaps**

Basemaps are the underlying maps used by Site Viewer.

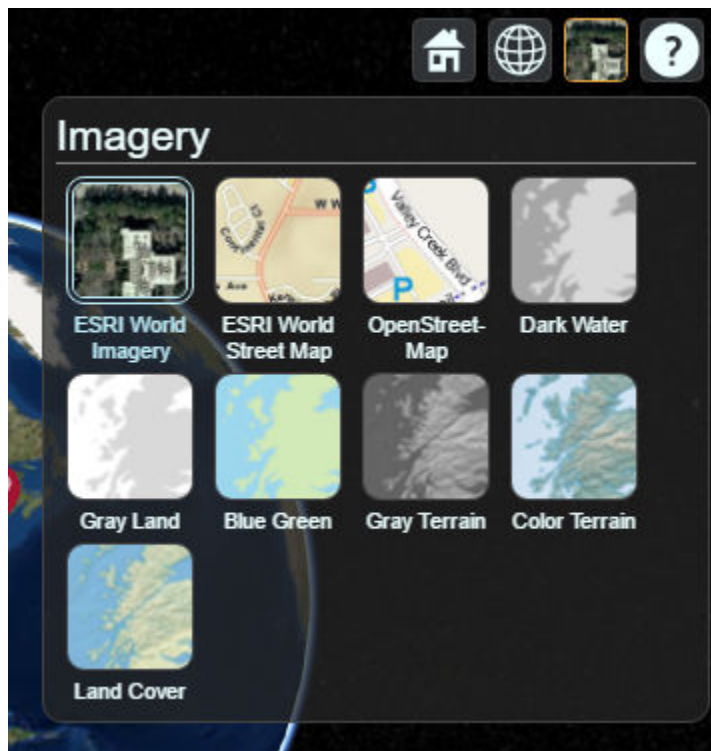

You can select the basemaps using the basemap picker. You need an active Internet connection for all basemaps except Dark Water. The following options are available:



- Satellites
- Streets
- OpenStreetMap
- Dark Water
- Gray Land
- Blue Green
- Gray Terrain
- Color Terrain
- Land Cover



By default, Site Viewer uses **Satellites**. You need an active Internet connection for all basemaps except **Dark Water**.

Use **Satellites** for high quality satellite imagery. Use **Streets**, or **OpenStreetMap** for imagery of roads, labels, and political boundaries.

Use The MathWorks® natural earth basemaps for low resolution but more controls and color scheme options in basemaps.

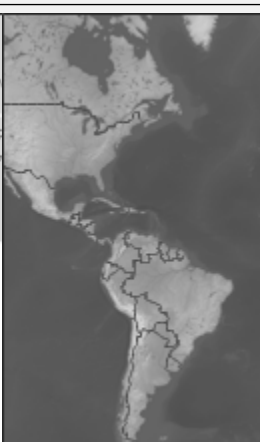
**Basemaps**

| Two-Tone Basemaps  | Description  | Natural Earth Basemaps  | Description  |
|--|--|---|--|
|   | <p>'darkwater'</p> <p>Land areas: light-to-moderate gray</p> <p>Ocean and water areas: darker gray</p> <p>This is the default map.</p> |   | <p>'colorterrain'</p> <p>Shaded relief combined with custom elevation colors based on climate—humid lowlands are green and arid lowlands brown.</p>  |
|  | <p>'grayland'</p> <p>Land areas: light-to-moderate gray land</p> <p>Ocean and water areas: white</p>                                   |  | <p>'grayterrain'</p> <p>Worldwide terrain depicted monochromatically in shades of gray, combining shaded relief that emphasizes both high mountains and the micro terrain found in lowlands.</p> |

| Two-Tone Basemaps   | Description  | Natural Earth Basemaps   | Description   |
|---|--|--|---|
|  | <p>'bluegreen'</p> <p>Land areas: light green</p> <p>Ocean and water areas: light blue</p> |  | <p>'Landcover'</p> <p>Satellite-derived land cover data and shaded relief presented with a light, natural palette suitable for making thematic and reference maps (includes ocean-bottom relief).</p> |

## View Latitude and Longitude Coordinates of Location

Use can now use Site Viewer to view the latitude and longitude coordinates of any location. To view the latitude and longitude, right click on the map and select **Show Location**.

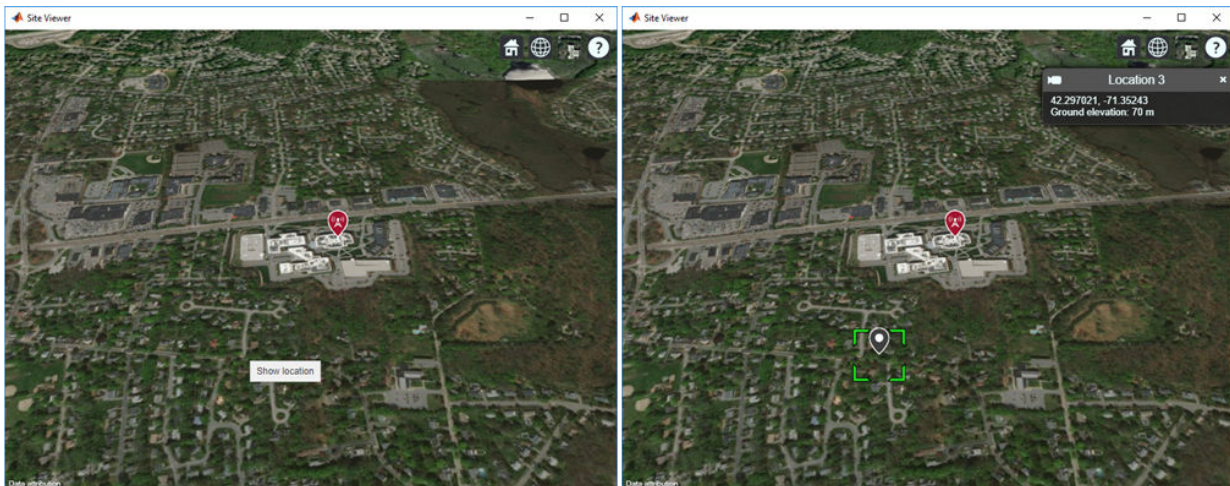



To remove the location, right-click on the location and select **Remove Location**.

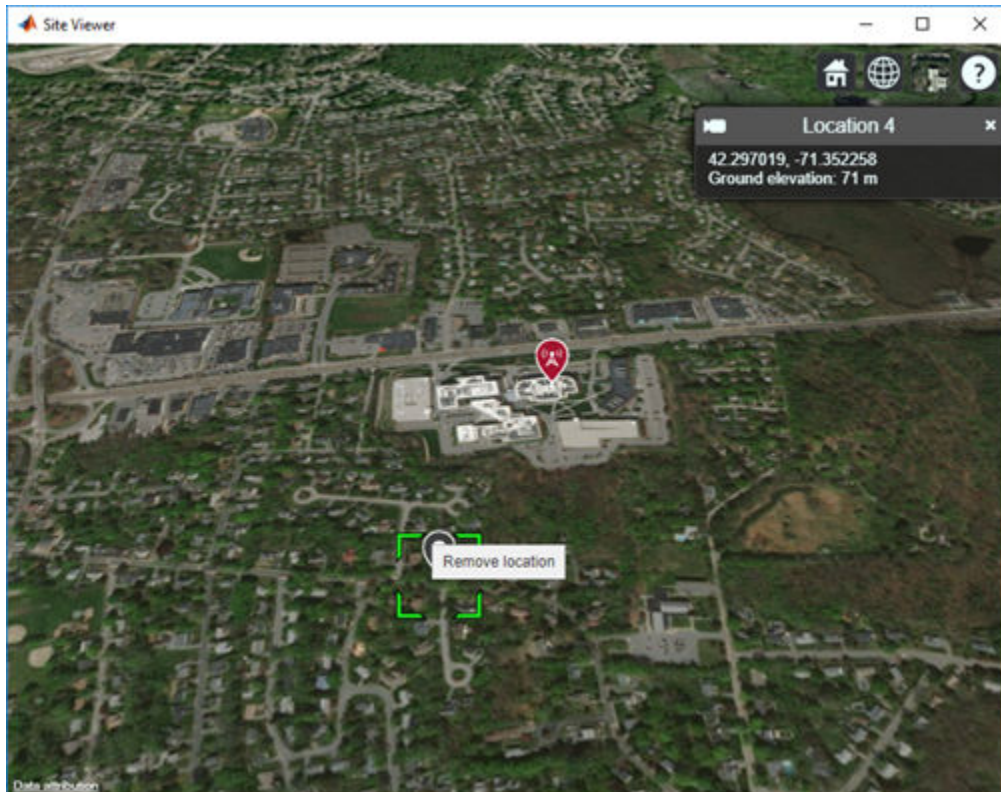

## See Also

opengl

## More About

- "Troubleshooting Site Viewer" on page 4-10
- "Access Basemaps and Terrain in Site Viewer" on page 4-12
- "System Requirements for Graphics" (MATLAB)
- "Resolving Low-Level Graphics Issues" (MATLAB)

## Troubleshooting Site Viewer

|  |
|--|
| <b>In this section...</b>                  |
| “Internet Connection Failure” on page 4-10 |
| “Graphics Environment” on page 4-10        |

### Internet Connection Failure

When you start Site Viewer up on showing a txsite or rxsite object, a check is made to make sure that you have an Internet connection to retrieve the default basemap and terrain data.

If Site Viewer cannot connect to the Internet the following warning messages are displayed:

- *Warning: Unable to access the Internet, showing Dark Water instead of Satellites. See Access Basemaps and Terrain in Site Viewer.*
- *Warning: Unable to access terrain data. See Access Basemaps and Terrain in Site Viewer.*

If Site Viewer cannot connect to the Internet, then terrain data is not used and the "Dark Water" basemap is selected.

### Graphics Environment

Site Viewer can fail to launch because of two reasons:

- In MATLAB®, OpenGL® is set to software graphics. An error message is displayed in the command window, notifying you to upgrade the graphics hardware driver or select hardware graphics using OpenGL.

For more information, see `opengl`, and “Resolving Low-Level Graphics Issues” (MATLAB).

- When starting Site Viewer, JavaScript® for WebGL support fails. An error message is displayed in the command window, notifying you to update the graphics hardware driver.

For more information, see “Resolving Low-Level Graphics Issues” (MATLAB)



## See Also

opengl

### More About

- “Site Viewer” on page 4-2
- “Access Basemaps and Terrain in Site Viewer” on page 4-12
- “System Requirements for Graphics” (MATLAB)
- “Resolving Low-Level Graphics Issues” (MATLAB)

## Access Basemaps and Terrain in Site Viewer

### In this section...

“Access and Download Basemaps” on page 4-12

“Access Terrain” on page 4-13

You need an active Internet connection for all basemaps except Dark Water.

### Access and Download Basemaps

To download MATLAB basemaps:

- 1 On the MATLAB **Home** tab, in the **Environment** section, click **Add-Ons > Get Add-Ons**.
- 2 In the Add-On Explorer, scroll to the **MathWorks Features** section, and click **show all** to find the basemap packages. You can also search for the basemap add-ons by name (listed in the following table) or click **Features** in **Filter by Type**.
- 3 Select the basemap data packages. For more information about basemaps, see geobubble.

| Basemap Name   | Basemap Data Package Name          |
|----------------|------------------------------------|
| 'bluegreen'    | MATLAB Basemap Data - bluegreen    |
| 'grayland'     | MATLAB Basemap Data - grayland     |
| 'colorterrain' | MATLAB Basemap Data - colorterrain |
| 'grayterrain'  | MATLAB Basemap Data - grayterrain  |
| 'landcover'    | MATLAB Basemap Data - landcover    |

In addition, Antenna Toolbox also supports three external basemaps that you can select the basemap picker. The following options are available:

- Satellites
- Streets
- OpenStreetMap

## **Access Terrain**

To access terrain data for Site Viewer, you need an active Internet connection.

## **See Also**

### **More About**

- “Site Viewer” on page 4-2
- “Troubleshooting Site Viewer” on page 4-10
- “System Requirements for Graphics” (MATLAB)
- “Resolving Low-Level Graphics Issues” (MATLAB)

## Access TIREM Software

The Terrain Integrated Rough Earth Model (TIREM) is a propagation model for computing the path loss for irregular terrain and seawater scenarios. TIREM is developed, trademarked, and licensed by Alion Science. To use TIREM, you need to acquire it from Alion Science.

TIREM is designed to calculate the reference basic median propagation loss (path loss) based on the terrain profile along the great circle path between two antennas for example using digital terrain elevation data (DTED). You can use TIREM model to calculate the point-to-point path loss between sites over irregular terrain. The model combines physics with empirical data to provide path loss estimates. The TIREM propagation model can predict path loss at frequencies between 1 MHz and 1 THz.

Use `tiremSetup` to enable TIREM access from within MATLAB. The TIREM library folder contains the `tirem3` shared library. The full library name is platform dependent:

| Platform | Shared library name |
|----------|---------------------|
| Windows  | libtirem3.dll       |
| Linux    | libtirem3.so        |
| Mac      | libtirem3.dylib     |

### See Also

`tiremSetup`